

FURUTEC®

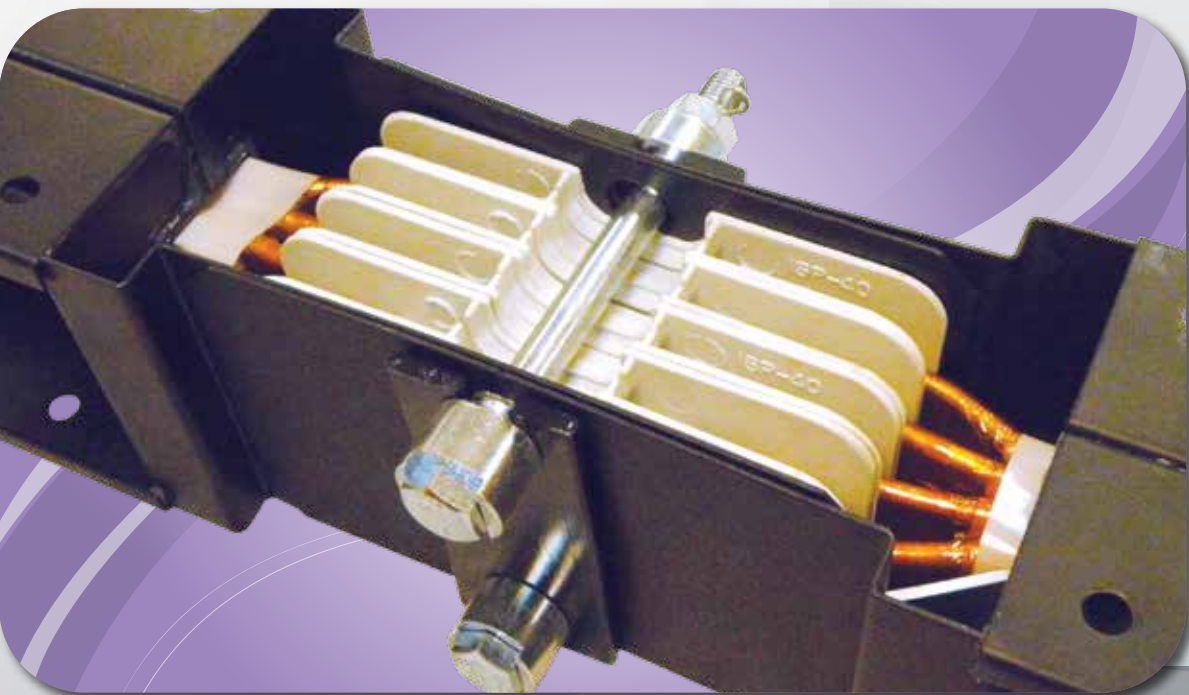

HP-ES

Busduct System

with Japanese technology

TABLE OF CONTENT

- About Furutec 02
- Busduct Design Layout 03-04
- Specification and Standards 05-10
- Physical Data**
 - Conductor Size 11
 - Flange End / Flange End Box 12-13
 - Flatwise Elbow / Edgewise Elbow 14
 - Flatwise Tee Elbow 15
 - Flatwise Offset Elbow / Edgewise Offset Elbow 16
 - Combination Elbow 17
 - Elbow with Flange End / Flange End Box 18
 - End Cap / End Closure 19
 - Vertical Spring Hanger / Vertical Hanger 20-21
 - Edgewise / Flatwise Hanger 22-23
 - Reducer 23
 - Expansion Unit 24
 - Flexible Link 25
 - Tap-Off Unit 26-27
- Design Factors** 28-30
- Installation & Maintenance Procedure**
 - Before Busduct Installation 31
 - During Busduct Installation
 - Busduct Joint 32
 - Tap Off Unit (Plug In Type) 33
 - Tap Off Unit (Bolt On Type) 34
 - Vertical Spring Hanger / Vertical Hanger 34
 - Edgewise / Flatwise Hanger 35
 - Connection with Equipment 35
 - After Busduct Installation 36
 - Recommended Maintenance Procedures 36-37

ABOUT FURUTEC

Furutec Electrical started to manufacture busduct system in Penang, Malaysia since 1995 under the license from Furukawa Electric, Japan. In 2008, EITA Resources Berhad ventured into designing and manufacturing busduct system and Furutec became a wholly-owned subsidiary of EITA Resources Berhad which is a public listed company in Malaysia.

Having benefitted from more than a decade-long of technical collaboration with Furukawa, Furutec is noted for its relentless and uncompromising commitment on quality and excellence as the Japanese manufacturing practice and culture have been firmly embedded into Furutec busduct system. Today, Furutec has more than 19 years of experience in the manufacturing of busduct system that meets international standards. This product is of the finest quality and reliability, utilising the stringent Japanese know-how and technology.

Our well-equipped R&D facilities have enabled us to continue to research and verify our product in accordance to the various requirements under IEC 60439-2 (old) and IEC 61439-6 (new) as well as the fire resistance aspect of the product.

Besides Furutec's in-house R&D activities, we also look outwards to find new opportunities and complement our in-house capabilities. We tap into local scientific expertise and gain useful insights for future growth through technical collaborations with public universities. To better capitalize on the home grown knowledge, Furutec Electrical has entered into a technical collaboration agreement with local university to jointly research and investigate the development of new raw materials used in the manufacturing of busduct system.

With the merit from this R&D effort, our full product range of copper HP-ES busduct (from 400A to 6300A) is eventually able to be successfully type-tested and certified by a reputable independent testing authority, KEMA/DEKRA in compliance to IEC 61439-6. Additionally, our tap-off unit is also type tested and certified to IEC 61439-6 for temperature rise test, short circuit test and thermal cycling test.

Type testing in accordance and compliance to IEC 61439-6

Construction

- Strength of materials and parts (10.2)
- Degree of protection of assemblies (10.3)
- Clearances and creepage distances (10.4)
- Protection against electric shock and integrity of protective circuits (10.5)
- Incorporation of switching devices and components (10.6)
- Internal electrical circuits and connections (10.7)
- Terminals for external conductors (10.8)

Performance

- Dielectric properties (10.9)
- Verification of temperature-rise (10.10)
- Short-circuit withstand strength (10.11)
- Electromagnetic compatibility – EMC (10.12)
- Mechanical operation (10.13)
- Resistance to flame-propagation (10.101)
- Fire resistance in building penetrations (10.102)

Furthermore, our product innovation and R&D have enabled us to stay ahead of competition and engineer new and optimized product that continues to meet our customer's expectation and trust towards our products. Through the expansion of our R&D activities, Furutec Electrical will continue to focus on 3 key areas namely product R&D, application R&D and process R&D.

Furutec is committed towards quality and services as stipulated in its ISO 9001:2008 Certification for Quality Management System.

Our product has been accepted globally and successfully installed in various prestigious projects in Malaysia as well as around the world. We take pride in further expanding our success to more countries through our regional distributors/business partners.

DEKRA



KEMA



BUSDUCT DESIGN LAYOUT

- | | | | |
|----|--------------------------------|----|------------------------|
| 1 | Edgewise Elbow with Flange End | 11 | Reducer |
| 2 | Busduct Straight Feeder | 12 | Vertical Spring Hanger |
| 3 | Combination Elbow | 13 | Tap Off Unit |
| 4 | Flatwise Offset | 14 | Vertical Hanger |
| 5 | Flatwise Elbow with Flange End | 15 | Flatwise Elbow |
| 6 | Flexible Link | 16 | Busduct Joint |
| 7 | Edgewise Offset | 17 | Edgewise Tee Elbow |
| 8 | Flange End Box | 18 | Edgewise Elbow |
| 9 | End Cap | 19 | End Closure |
| 10 | Tap Box | | |

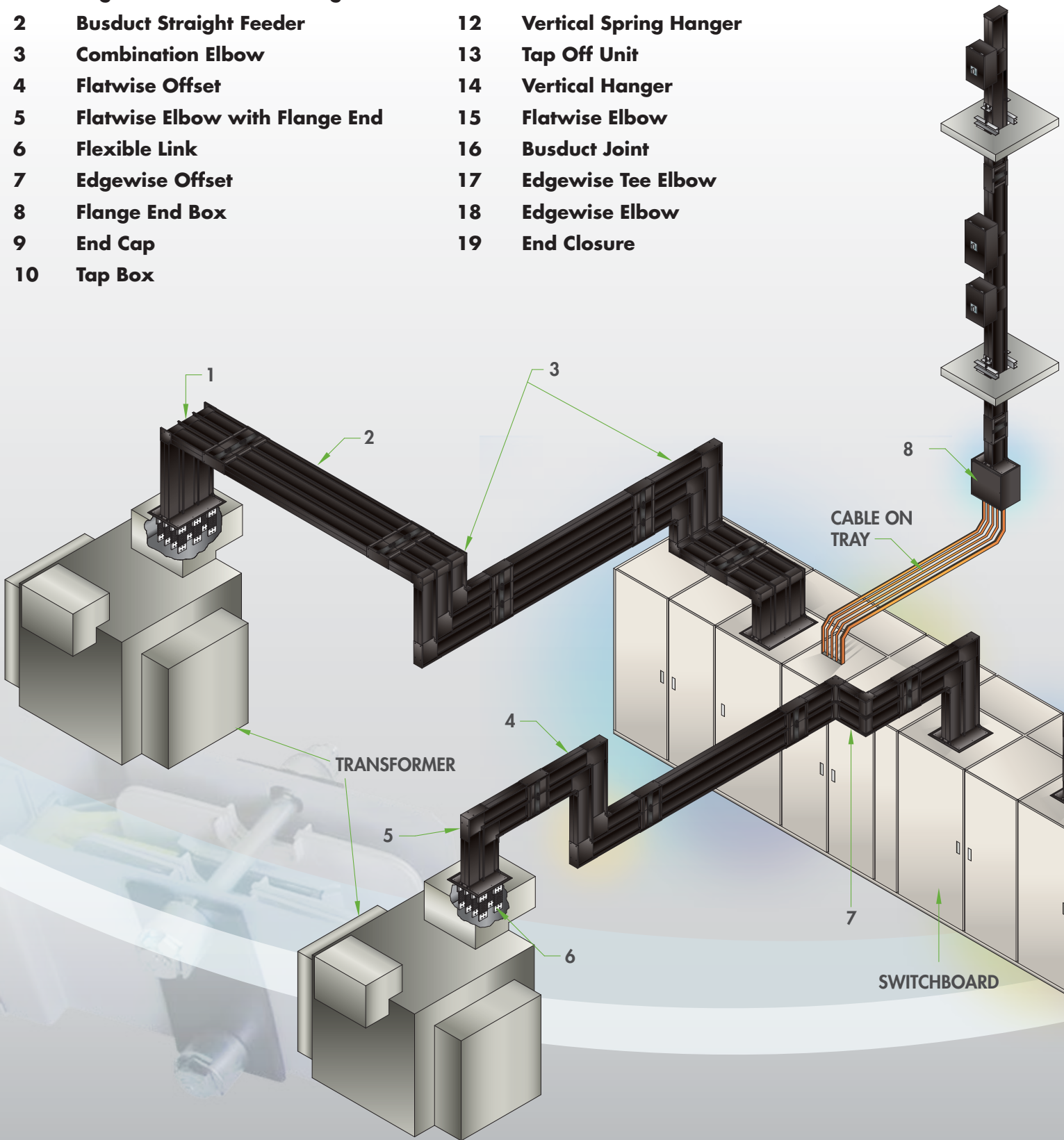

Furutec's Building Information Modelling (BIM) is ready for better and more effective project fulfillment.

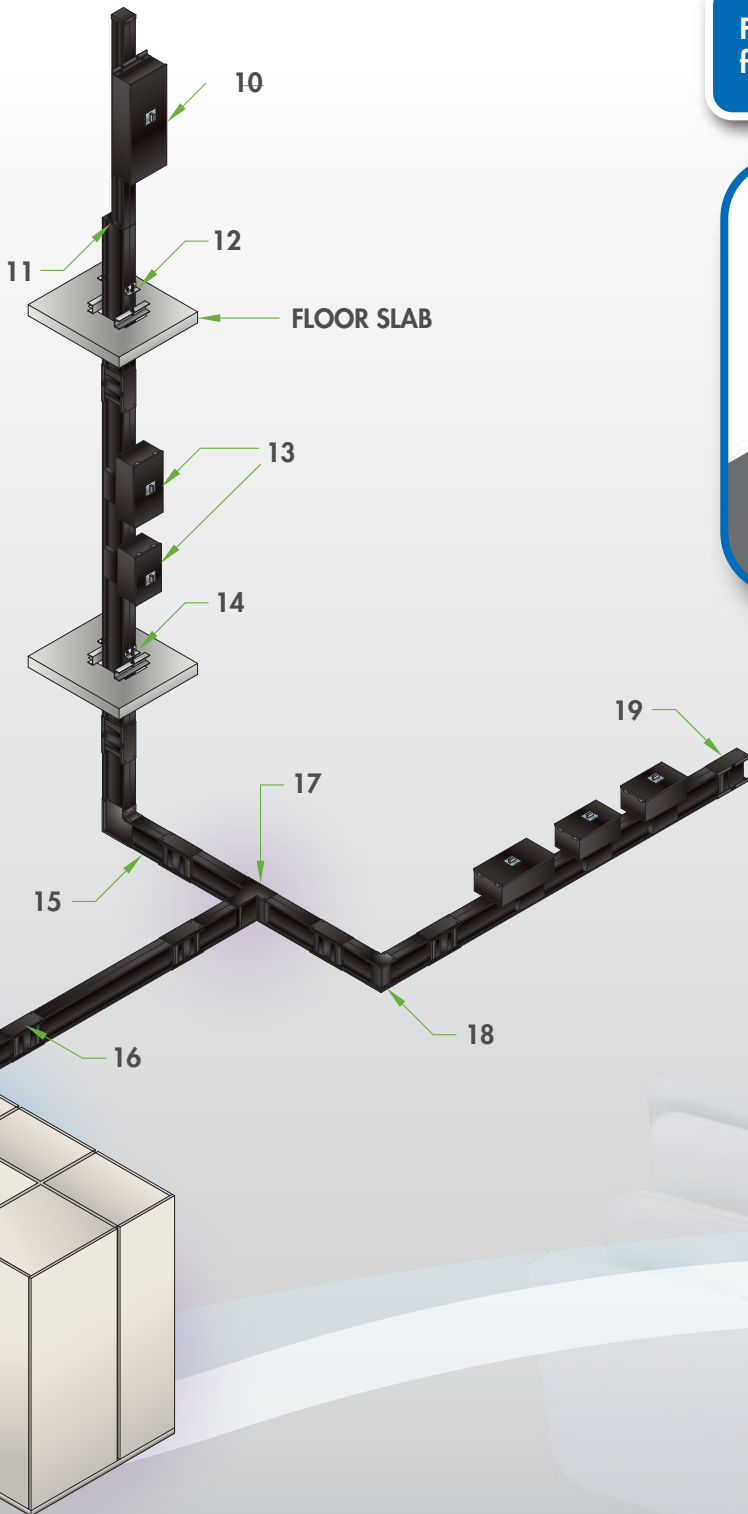
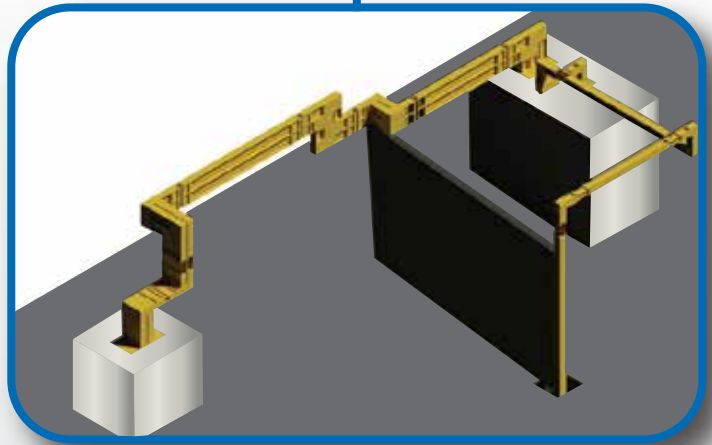

Advantages of BIM:

- 3D visualization
- Change management
- Building simulation
- Data management
- Building operation
- Minimizing human error
- Lesser time consumption

SPECIFICATION & STANDARDS

General

Furutec HP-ES busduct system is designed to meet the requirement of commercial, industrial and residential applications. It carries up to 6300A with reduced energy losses and heat as compared with the conventional cable system.

Furutec busduct system is known for :

- 1) Flexible and modular in design.
- 2) Occupying lesser space.
- 3) Fast installation and lower installation cost and easy maintenance.
- 4) Lower voltage drop.
- 5) Low power frequency magnetic field.
- 6) Fire resistance (optional) and non-flammable propagation.
- 7) Flexibility for future expansion.
- 8) Strong mechanical strength and higher short-circuit rating.
- 9) Higher degree of protection.

Design Standards

Furutec busduct system is designed and manufactured in accordance to the following international standards :

- IEC 61439-6** Low Voltage Switchgear and Controlgear Assemblies - Part 6: Busbar Trunking Systems (Busways).
- IEC 61439-1** Low Voltage Switchgear and Controlgear Assemblies - Part 1: General Rules.

Optional standards for fire-rated busduct system :

BS 6387:1994

Performance Requirements for Cables required to Maintain Circuit Integrity under Fire Conditions (Adoption).

JIS C 8364 & JIS A 1304

Japanese Industrial Standards for Busway's Method of Fire Resistance Test for Structural Parts of Buildings.

CNS 14286

(Equivalent to JIS C 8364 & JIS A 1304)
Fire Resistance Test

System Voltage & Rated Current

Furutec busduct system provides a flexible and reliable electrical distribution system with a wide range of current carrying capacity from 400A to 6300A with operating voltage up to 690V.



SPECIFICATION & STANDARDS

System Configuration and Phase Sequence

The compact sandwich design of Furutec busduct can be configured to 3-phase 3-wire (3P3W), 3-phase 4-wire (3P4W) or 3-phase 5-wire (3P5W with integral earth bar).

Due to the existence of non-linear loads in today's modern buildings, high harmonic neutral current overheats the neutral conductor and deteriorate the performance and life span of equipment. 200% neutral bar is offered to handle the overheating and increased neutral current caused by the harmonic effect.

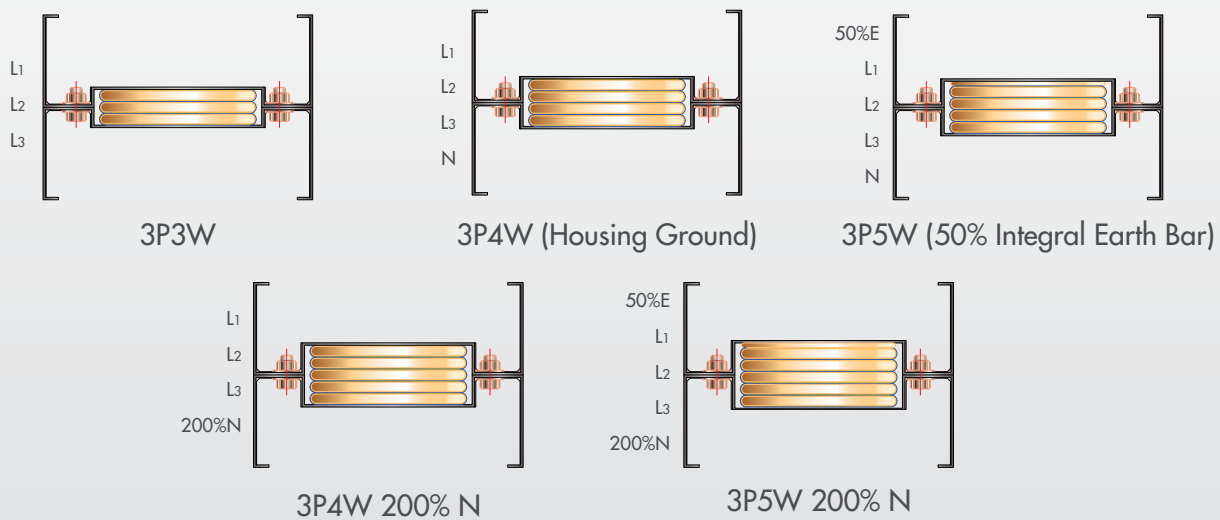

Conductor and Insulation Material

Copper and aluminium conductor are of the conductivity 99.98% and 60% respectively. It meets all electrical, thermal and mechanical properties and comply to the relevant international standards, such as JIS H3140, ASTM B187M, BS EN 13601, etc.

Each copper and aluminium conductor (except at joint parts) is insulated with polyester films (-70°C to +150°C). The rated insulation voltage is up to 1000V at 50Hz or 60Hz of frequency. Each conductor is tin-plated to provide protection from corrosion and high conductivity.

Busduct Housing

Furutec busduct system is of the low impedance type and totally enclosed for protection against mechanical damage and dust accumulation. The busduct housing is made of Electro-Galvanized sheet steel with epoxy powder coating.

Conductors are fully enclosed with the busduct housing, which provides an excellent heat dissipation, thus improving the power transmission efficiency and reducing voltage drop. The construction of busduct housing is compact and robust in design to meet the rated short-circuit ratings.

SPECIFICATION & STANDARDS

Busduct Joint System

Furutec busduct joint features a maintenance free **double-bolt joint design**. This double-bolt joint system ensures a sufficient electrical contact area and good mechanical strength. Its high tensile clamping bolts in duct-to-duct jointing do not penetrate through the conductors. A spring steel material named as leaf spring that is wider than the conductors, is used to ensure a sufficient pressure on conductor contact area. This clamped joint having benefitted from a decade-long Japanese Technology generates less heat at busduct joint as compared to bolted joint system, which necessitate the drilling or punching of holes through the conductors with the bolt holes causing distortion to the lines of current flow. This clamped joint with leaf springs also has a more even contact pressure than the one using bolt-through joint.

Busduct Joint Installation (IP42 and IP65)

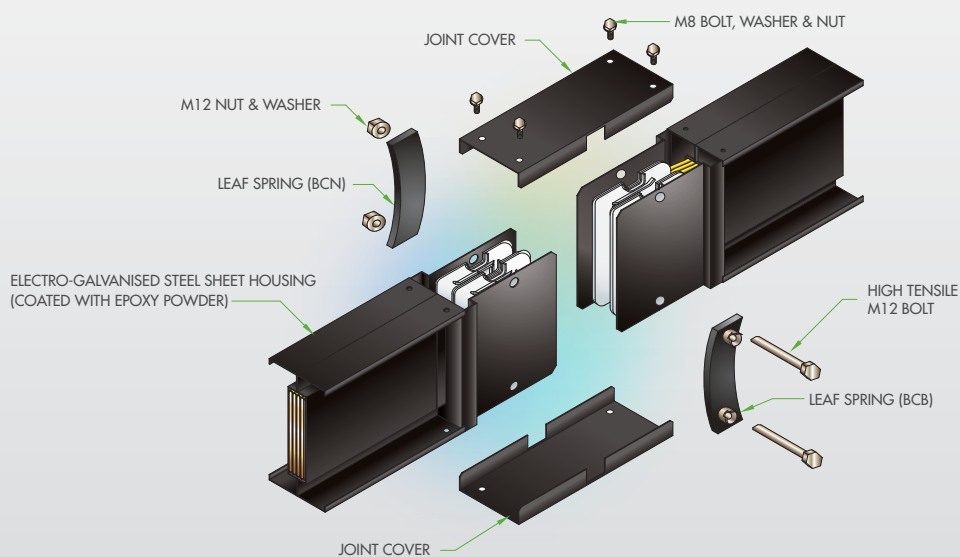

Busduct Joint Installation (IP66)

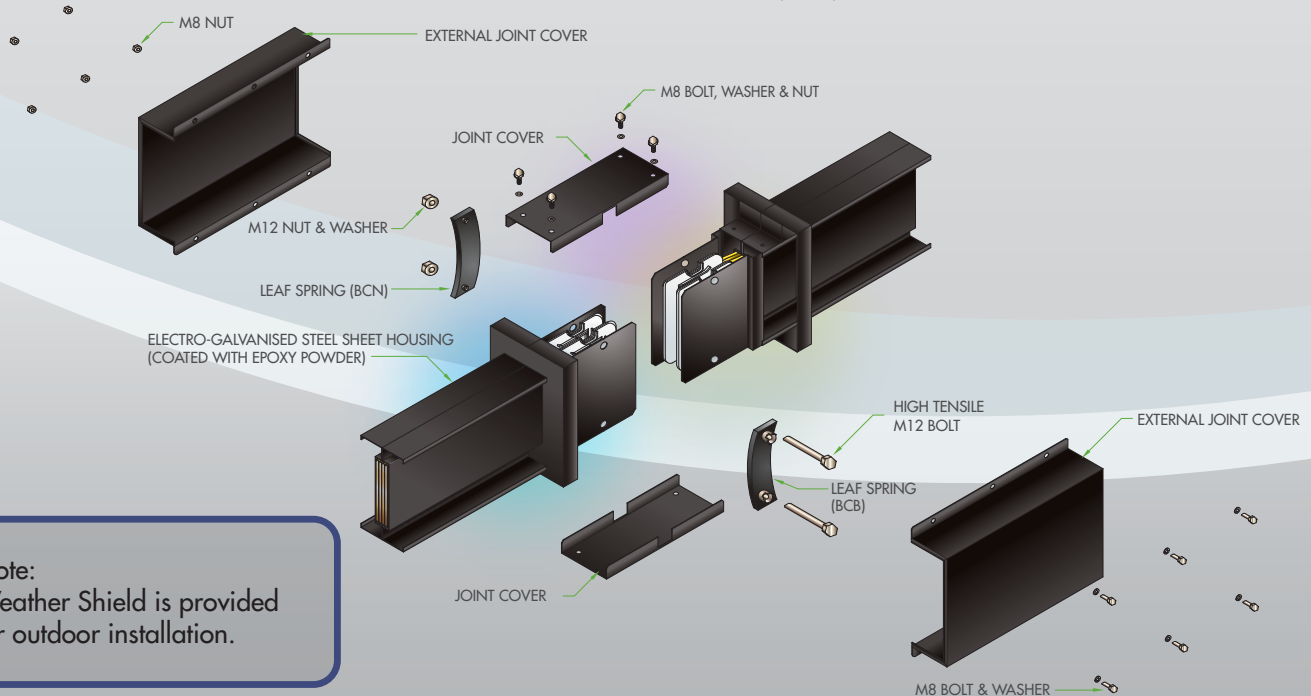

Note:
Weather Shield is provided
for outdoor installation.

SPECIFICATION & STANDARDS

Method of Mounting

For horizontal busduct installation, the edgewise / flatwise hanger or flat hanging clamp shall be installed in every 1500mm interval.

Vertical busduct system shall be supported adequately with vertical spring hanger / vertical hanger on each floor. Intermediate supports shall be provided if floor height exceeds 5000mm.

Degree of Protection

Furutec busduct housing is designed and constructed to meet the requirement of indoor and outdoor installation. The degree of protection of Furutec busduct housing is verified and tested to meet the requirement of IP42, IP65 and IP66 in accordance to IEC 60529 by independent testing authority.

The IP classification is categorized into 2 parts; **The first digit denotes protection against ingress of solid objects** and **the second digit denotes protection against water**.

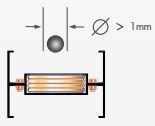
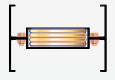
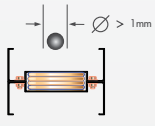
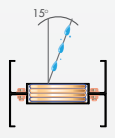
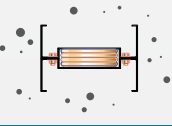
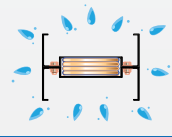
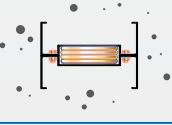
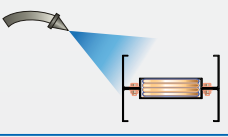
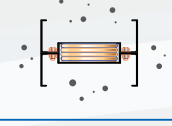
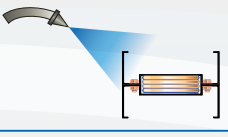
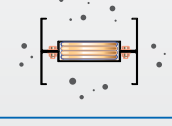
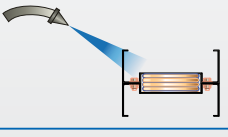
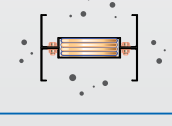
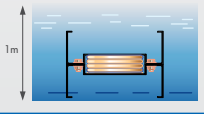
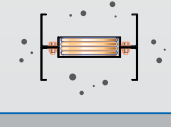
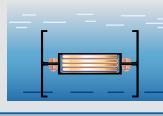
Protection against ingress of solid objects		Protection against water	
4	Protected against foreign objects greater than 1mm 	0	No protection 
4	Protected against foreign objects greater than 1mm 	2	Drops of water falling at up to 15° from the vertical 
5	Dust protected 	4	Projected water from all directions (limited ingress permitted) 
5	Dust protected 	5	Jets of water (limited ingress permitted) 
6	Dust tight 	5	Jets of water (limited ingress permitted) 
6	Dust tight 	6	Heavy jets of water (limited ingress permitted) 
6	Dust tight 	7	Effects of immersion between 15cm and 1m 
6	Dust tight 	8	Long period of immersion under pressure 

SPECIFICATION & STANDARDS

Temperature Rise Limit

The temperature rise at any points of the external metal surface of busduct housing will not exceed 55°C above ambient temperature.

The temperature rise at any points of external insulated conductors will not exceed 70°C above ambient temperature when operating at rated load current.

Both parameters are in line with IEC61439-6 and IEC61439-1.

Furutec busduct system is able to operate at full rated current at a maximum ambient air temperature of 40°C without any derating effects. When busduct system is installed in a higher ambient temperature, its current rating will be derated.

Short-Circuit Strength

Copper Busduct :

Busduct Rating	Short Circuit Rating (kA/1 Sec)	Short Circuit Rating (kA/3 Sec)
400A	20	11
600A	20	11
700A	35	20
800A	45	25
1000A	55	31
1250A	65	50
1600A	65	50
1800A	65	50
2000A	85	50
2200A	85	50
2500A	85	50
3000A	120	70
3500A	120	70
4000A	120	70
4500A	120	70
5000A	120	70
6300A	150	87

Aluminium Busduct :

Busduct Rating	Short Circuit Rating (kA/1 Sec)	Short Circuit Rating (kA/3 Sec)
400A	15	8
500A	20	11
700A	20	11
800A	40	23
1000A	40	23
1300A	55	31
1500A	55	31
1600A	60	34
1800A	60	34
2200A	60	34
2500A	100	58
3000A	100	58
3200A	100	58
3500A	100	58
4000A	120	70
4500A	120	70
5000A	120	70
6000A	120	70

Voltage Drop

Due to low impedance, the voltage drop of busduct system is lower compared with the conventional cable system. Therefore, busduct system is a more efficient power transmission media as compared with the conventional cable system.

Voltage Drop Calculation :

$$\frac{1 + \alpha \left(55 \times \left(\frac{I}{I_0} \right)^2 + 20 \right)}{1 + 75\alpha}$$

ΔV = Line-to-Line Voltage Drop (V/m)

I = Load Current (A)

I_0 = Rated Current (A)

$\cos\phi$ = Load Power Factor

$\sin\phi$ = $\sqrt{1 - \cos^2\phi}$

R = AC resistance at load current (Ω/m)

R_0 = AC resistance at rated current (I_0) (Ω/m)

α = Temperature coefficient of conductor at 20 °C
= 3.85×10^{-3} (Copper)

X = Reactance (Ω/m)

Note: Consult Furutec Electrical for the voltage drop calculation of copper and aluminium busduct.

SPECIFICATION & STANDARDS

Fire Resistant / Busduct System

Fire Resistant Busduct is provided as an option for the incoming and outgoing circuits of emergency main switchboard. The copper conductor of fire resistant busduct is insulated with 2 layers of mica tape and 2 layers of polyester film.

Besides complying to resistance to flame propagation (10.101) and fire resistance in building penetration (10.102) stated in IEC61439-6, Furutec busduct system has also been type tested to BS 6387:1994 (Performance Requirement of maintaining circuit integrity during fire conditions) by independent testing authority.

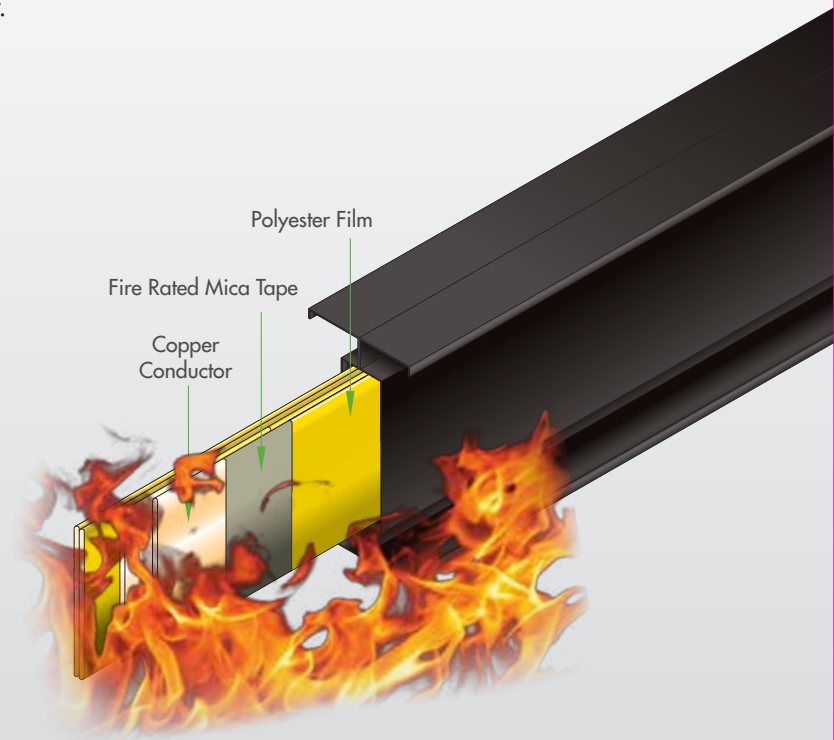
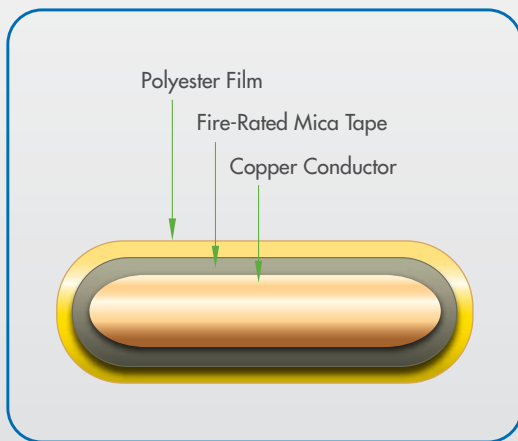

BS 6387:1994 Category 'C' (Resistance to Fire Alone Test)

Flame Temperature	: 950°C
Test Voltage	: 660V
Test Duration	: 3 hours (180 minutes)

Other fire resistant test

CNS 14286 (Equivalent to JIS C 8364 & JIS A 1304)

Flame Temperature	: 840°C
Test Voltage	: 600V
Test Duration	: 30 minutes

Test Furnace:

Large scale fire resistant furnace where the busduct sample is heated up to 840°C from all directions.

Note: Fire Resistant Busduct is applicable to copper conductor only.

PHYSICAL DATA

HP-ES BUSDUCT

Conductor Size

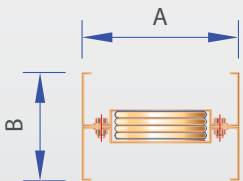
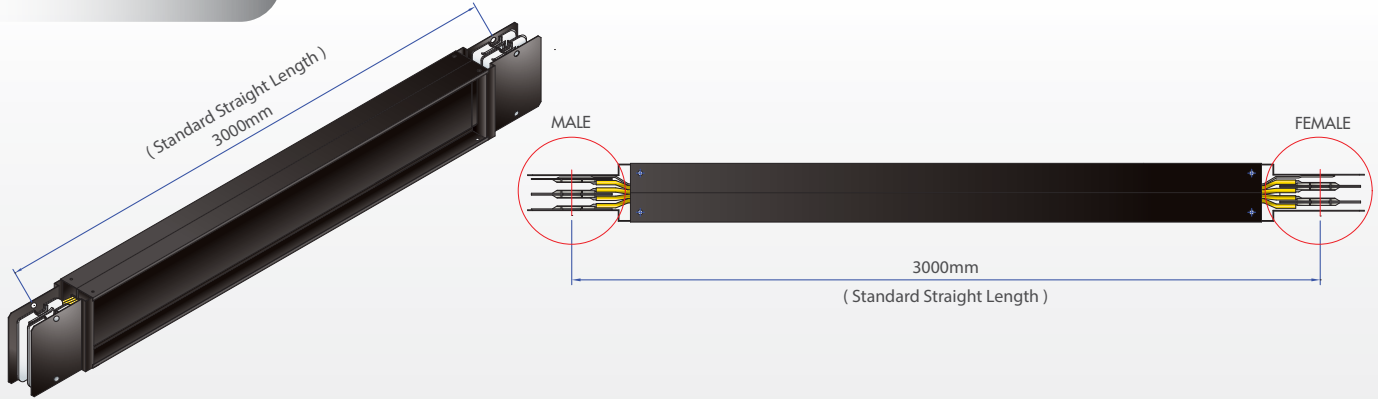

400A - 2500A (Copper)
400A - 2200A (Aluminium)

Figure 1

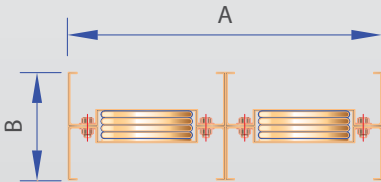

3000A - 5000A (Copper)
2500A - 4000A (Aluminium)

Figure 2

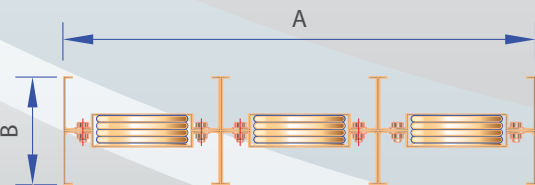

6300A (Copper)
4500A - 6000A (Aluminium)

Figure 3

Copper Busduct :

Busduct Rating	Model No.	A (mm)	B (mm)		Figure	Conductor Size per Phase (mm)	Total Weight (kg/meter)			
		3P3W 3P4W 3P4W+E 3P5W	3P3W	3P4W 3P4W+E 3P5W			3P3W	3P4W	3P5W 3P4W+E	
400A	HP-ES400C	115	100	120	1	One - 6 x 20	10.26	11.44	11.98	
600A	HP-ES600C	115				One - 6 x 30	11.94	13.67	14.49	
700A	HP-ES700C	115				One - 6 x 40	13.62	15.92	17.01	
800A	HP-ES800C	120				One - 6 x 45	14.56	17.14	18.35	
1000A	HP-ES1000C	135				One - 6 x 60	17.43	20.84	22.46	
1250A	HP-ES1250C	150				One - 6 x 75	20.49	24.75	26.78	
1600A	HP-ES1600C	185				One - 6 x 110	27.25	33.46	36.44	
1800A	HP-ES1800C	200				One - 6 x 125	30.39	37.45	40.84	
2000A	HP-ES2000C	225				One - 6 x 150	35.26	43.71	47.77	
2200A	HP-ES2200C	250				One - 6 x 175	40.41	50.27	55.00	
2500A	HP-ES2500C	275				One - 6 x 200	45.34	56.61	62.02	
3000A	HP-ES3000C	370				2	Two - 6 x 110	54.50	66.93	72.88
3500A	HP-ES3500C	400					Two - 6 x 125	60.79	74.91	81.68
4000A	HP-ES4000C	450					Two - 6 x 150	70.51	87.43	95.55
4500A	HP-ES4500C	500					Two - 6 x 175	80.81	100.53	110.01
5000A	HP-ES5000C	550				3	Two - 6 x 200	90.67	113.21	124.04
6300A	HP-ES6300C	750	Three - 6 x 175	120.04	149.59		163.80			

Aluminium Busduct :

Busduct Rating	Model No.	A (mm)	B (mm)		Figure	Conductor Size per Phase (mm)	Total Weight (kg/meter)			
		3P3W 3P4W 3P4W+E 3P5W	3P3W	3P4W 3P4W+E 3P5W			3P3W	3P4W	3P5W 3P4W+E	
400A	HP-ES400A	115	100	120	1	One - 6 x 30	8.56	9.17	9.42	
500A	HP-ES500A	115				One - 6 x 40	9.12	9.91	10.25	
700A	HP-ES700A	125				One - 6 x 50	9.90	10.88	11.29	
800A	HP-ES800A	150				One - 6 x 75	12.04	13.49	14.11	
1000A	HP-ES1000A	175				One - 6 x 100	14.14	16.05	16.88	
1300A	HP-ES1300A	200				One - 6 x 125	16.31	18.68	19.71	
1500A	HP-ES1500A	225				One - 6 x 150	18.44	21.26	22.51	
1600A	HP-ES1600A	250				One - 6 x 175	20.69	23.98	25.43	
1800A	HP-ES1800A	275				One - 6 x 200	22.90	26.66	28.32	
2200A	HP-ES2200A	315				One - 6 x 240	26.32	30.80	32.79	
2500A	HP-ES2500A	400				2	Two - 6 x 125	32.62	37.36	39.43
3000A	HP-ES3000A	450					Two - 6 x 150	36.88	42.52	45.01
3200A	HP-ES3200A	500					Two - 6 x 175	41.38	47.96	50.86
3500A	HP-ES3500A	550					Two - 6 x 200	45.81	53.33	56.64
4000A	HP-ES4000A	630				3	Two - 6 x 240	52.63	61.59	65.57
4500A	HP-ES4500A	675					Three - 6 x 150	55.43	63.95	67.68
5000A	HP-ES5000A	780	Three - 6 x 185	64.82	75.22		79.83			
6000A	HP-ES6000A	945	Three - 6 x 240	78.95	92.39	98.36				

Flange End / Flange End Box

400A~2500A Flange End (Copper)
400A~2200A Flange End (Aluminium)

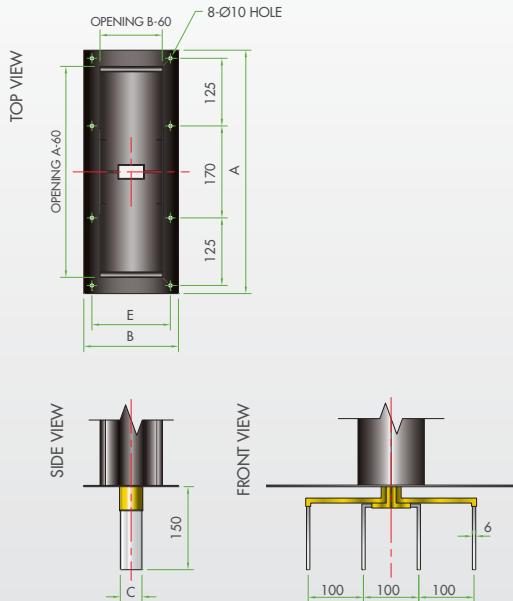

400A~2500A Flange End Box (Copper)
400A~2200A Flange End Box (Aluminium)

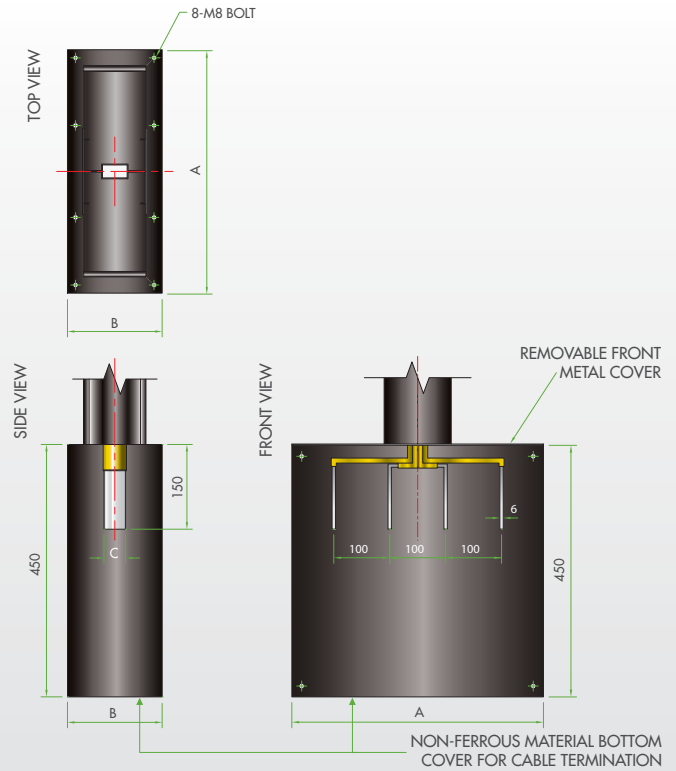

3000A~5000A Flange End (Copper)
2500A~4000A Flange End (Aluminium)

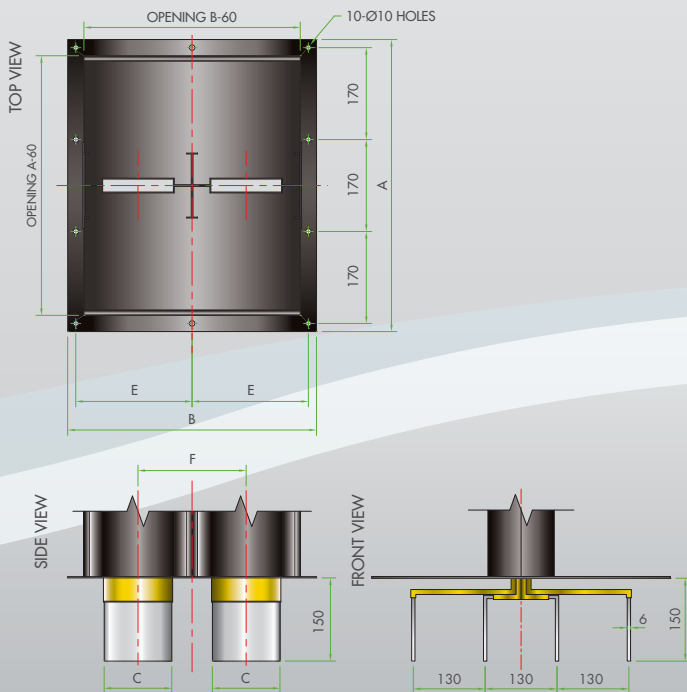

3000A~5000A Flange End Box (Copper)
2500A~4000A Flange End Box (Aluminium)

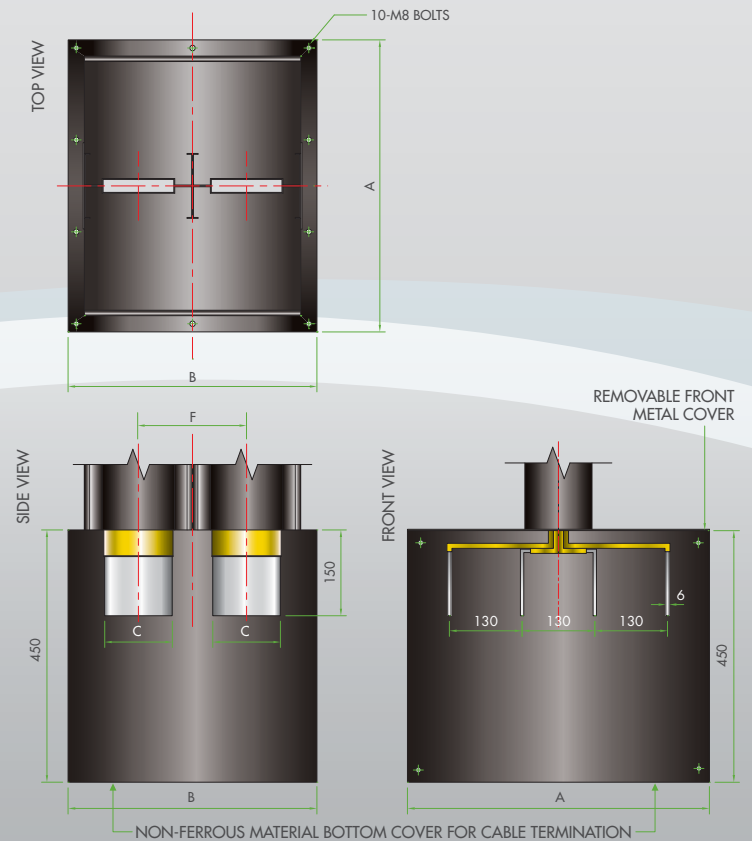

PHYSICAL DATA

6300A Flange End (Copper) 4500A - 6000A Flange End (Aluminium)

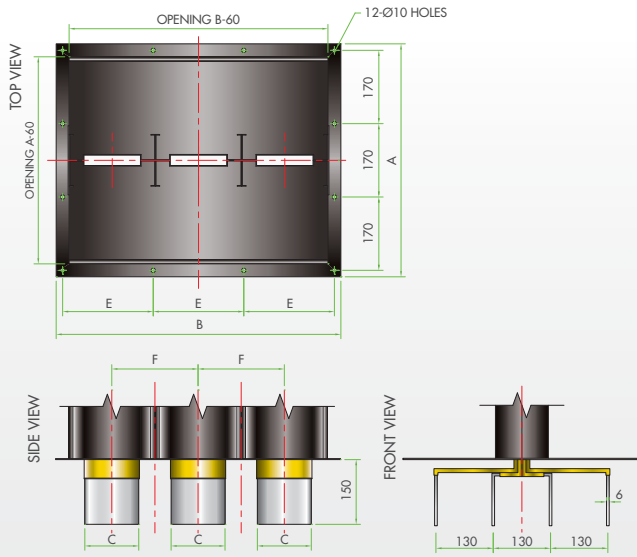

6300A Flange End Box (Copper) 4500A - 6000A Flange End Box (Aluminium)

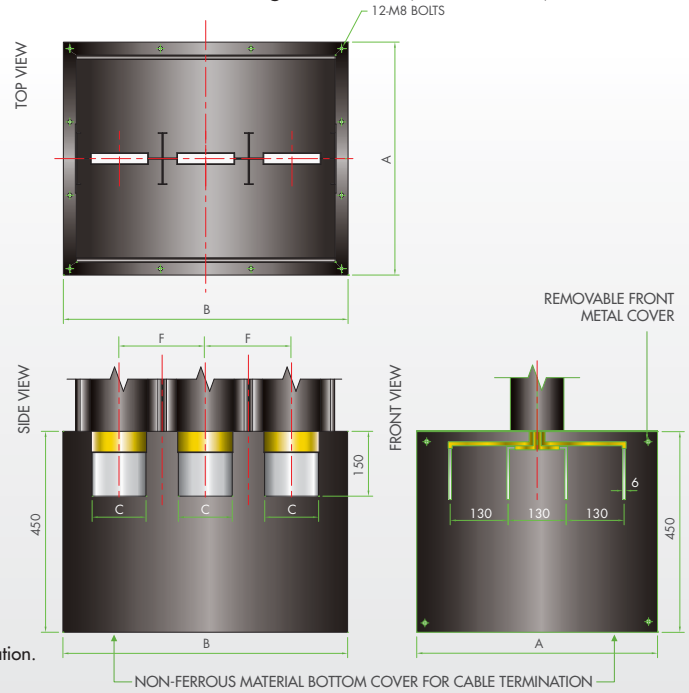

Busbar hole of Flange End / Flange End box is designed for switchboard / cable termination. Refer to Flexible Link on page 25 for Flange End termination at transformer.

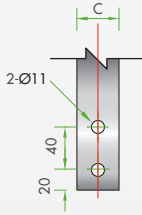

Fig. 1

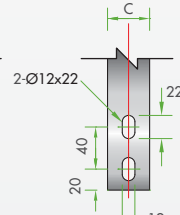

Fig. 2

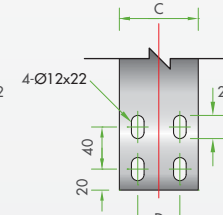

Fig. 3

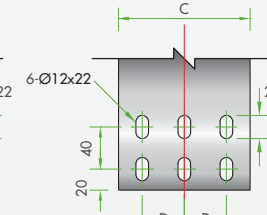

Fig. 4

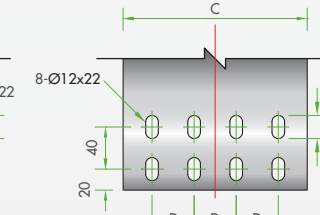

Fig. 5

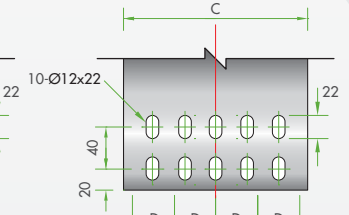
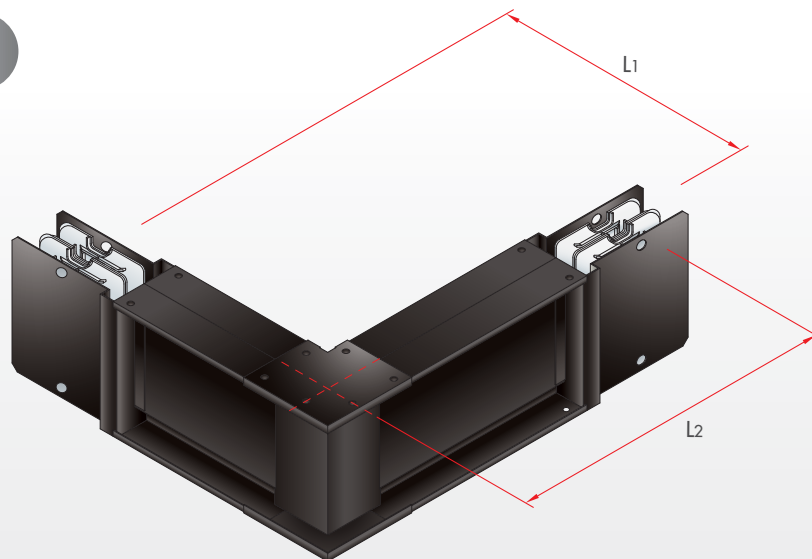

Fig. 6

Busduct Rating		Figure	A (mm)		B (mm)	C (mm)	D (mm)	E (mm)	F (mm)
Copper	Aluminium		3P3W	3P4W 3P4W+E 3P5W					
400A		1	350	450	175	20	-	145	-
600A	400A	1			175	30	-	145	-
700A	500A	2			175	40	-	145	-
800A		2			180	45	-	150	-
	700A	2			185	50	-	155	-
1000A		2			195	60	-	165	-
1250A	800A	3			210	75	40	180	-
	1000A	3			235	100	50	205	-
1600A		3			245	110	50	215	-
1800A	1300A	4			260	125	40	230	-
2000A	1500A	4			285	150	50	255	-
2200A	1600A	5			310	175	40	280	-
2500A	1800A	5	335	200	50	305	-		
	2200A	6	375	240	45	345	-		
3000A		3	410	540	430	110	50	200	185
3500A	2500A	4			460	125	40	215	200
4000A	3000A	4			510	150	50	240	225
4500A	3200A	5			560	175	40	265	250
5000A	3500A	5			610	200	50	290	275
	4000A	6			690	240	45	330	315
	4500A	4			735	150	50	235	225
6300A		5			810	175	40	260	250
	5000A	5			840	185	45	270	260
	6000A	6			1005	240	45	325	315

PHYSICAL DATA

Edgewise Elbow



Busduct Rating		Standard Lengths L1 x L2 (mm)	Minimum Lengths L1 x L2 (mm)
Copper	Aluminium		
400A to 6300A	400A to 6000A	400 x 400	290 x 290

Maximum length of edgewise elbow (L1 + L2) is 2500mm

Flatwise Elbow

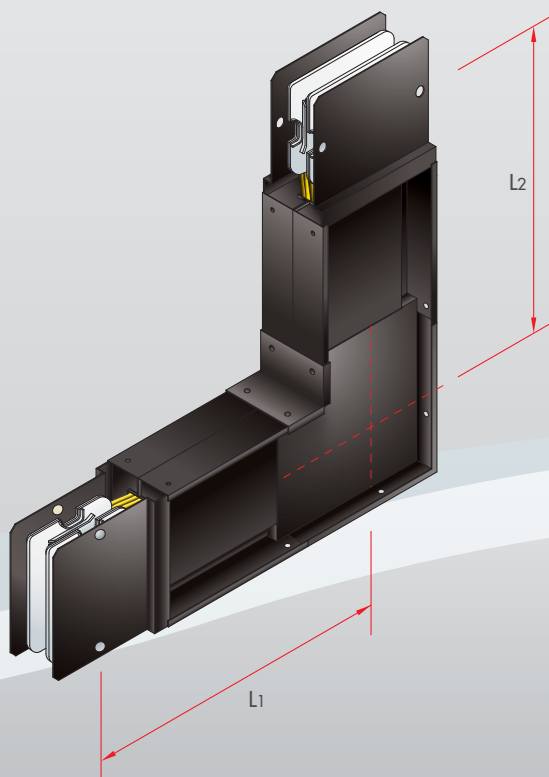

Busduct Rating		Standard Lengths L1 x L2 (mm)	Minimum Lengths L1 x L2 (mm)
Copper	Aluminium		
400A		400 x 400	320 x 320
600A	400A		320 x 320
700A	500A		320 x 320
800A			320 x 320
	700A		325 x 325
1000A			330 x 330
1250A	800A		335 x 335
	1000A		350 x 350
1600A			355 x 355
1800A	1300A		360 x 360
2000A	1500A		375 x 375
2200A	1600A		385 x 385
2500A	1800A		400 x 400
	2200A		420 x 420
3000A		600 x 600	445 x 445
3500A	2500A		460 x 460
4000A	3000A		485 x 485
4500A	3200A		510 x 510
5000A	3500A		535 x 535
	4000A		575 x 575
	4500A		600 x 600
6300A		750 x 750	635 x 635
	5000A		650 x 650
	6000A		735 x 735

Maximum length of flatwise elbow (L1 + L2) is 2500mm

Note : The above busduct length is designed for IP42 and IP65 Busduct system. The details of IP66 and weather shield design can be requested from Furutec Electrical.

PHYSICAL DATA

Flawise Tee Elbow

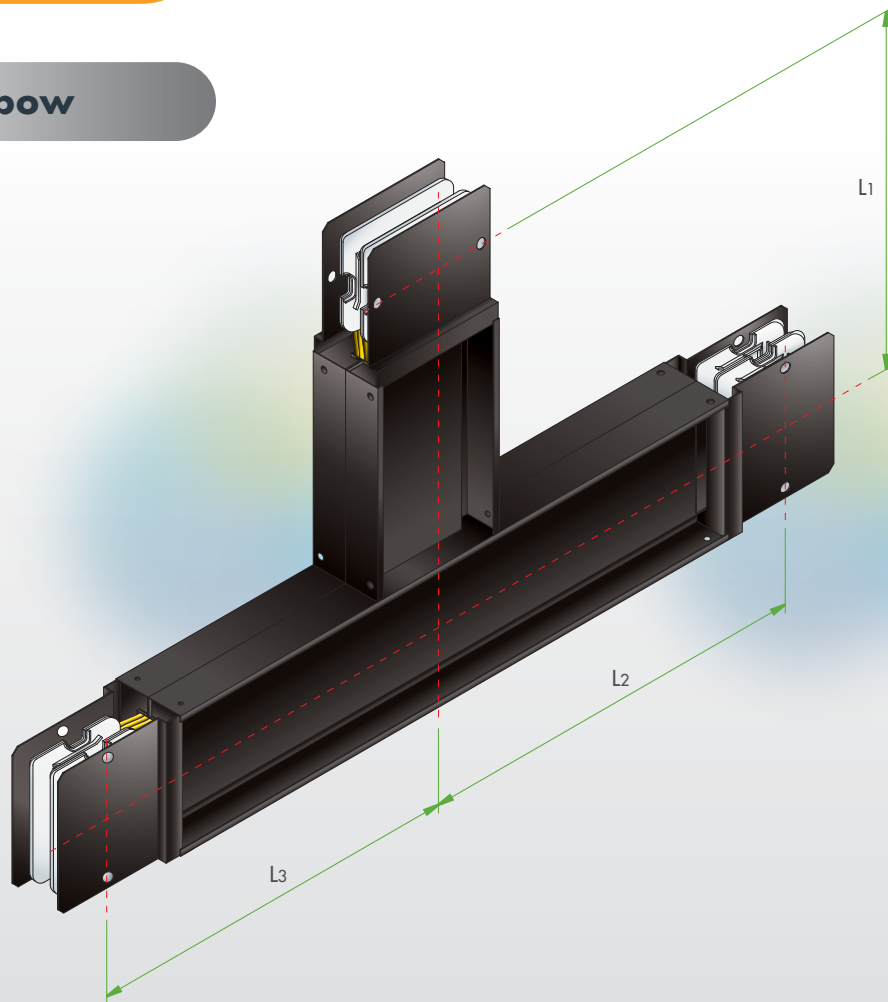

Busduct Rating		Standard Lengths L1 x L2 x L3 (mm)	Minimum Lengths L1 x L2 x L3 (mm)
Copper	Aluminium		
400A		400 x 400 X 400	290 x 290 x 290
600A	400A		290 x 290 x 290
700A	500A		290 x 290 x 290
800A			290 x 290 x 290
	700A		295 x 295 x 295
1000A			300 x 300 x 300
1250A	800A		305 x 305 x 305
	1000A		320 x 320 x 320
1600A			325 x 325 x 325
1800A	1300A		330 x 330 x 330
2000A	1500A		345 x 345 x 345
2200A	1600A		355 x 355 x 355
2500A	1800A		370 x 370 x 370
	2200A		390 x 390 x 390
3000A		600 x 600 x 600	415 x 415 x 415
3500A	2500A		430 x 430 x 430
4000A	3000A		455 x 455 x 455
4500A	3200A		480 x 480 x 480
5000A	3500A		505 x 505 x 505
	4000A		545 x 545 x 545
	4500A		570 x 570 x 570
6300A		750 x 750 x 750	605 x 605 x 605
	5000A		620 x 620 x 620
	6000A		705 x 705 x 705

Maximum length of TEE elbow (L1 + L2 + L3) is 2500mm

- Note : 1. The above busduct length is designed for IP42 and IP65 Busduct system. The details of IP66 and weather shield design can be requested from Furutec Electrical.
 2. The details of Edgewise Tee Elbow can be requested from Furutec Electrical.

Flawise Offset Elbow / Edgewise Offset Elbow

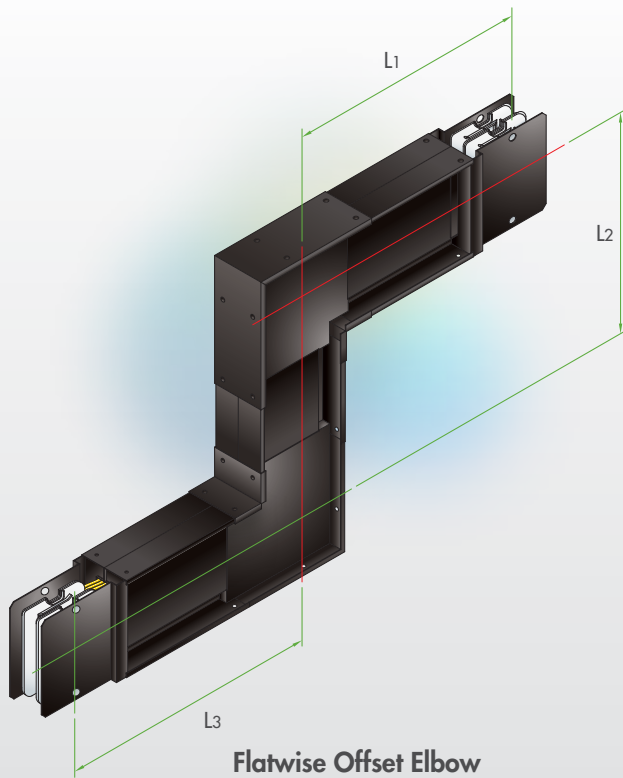

Flatwise Offset Elbow

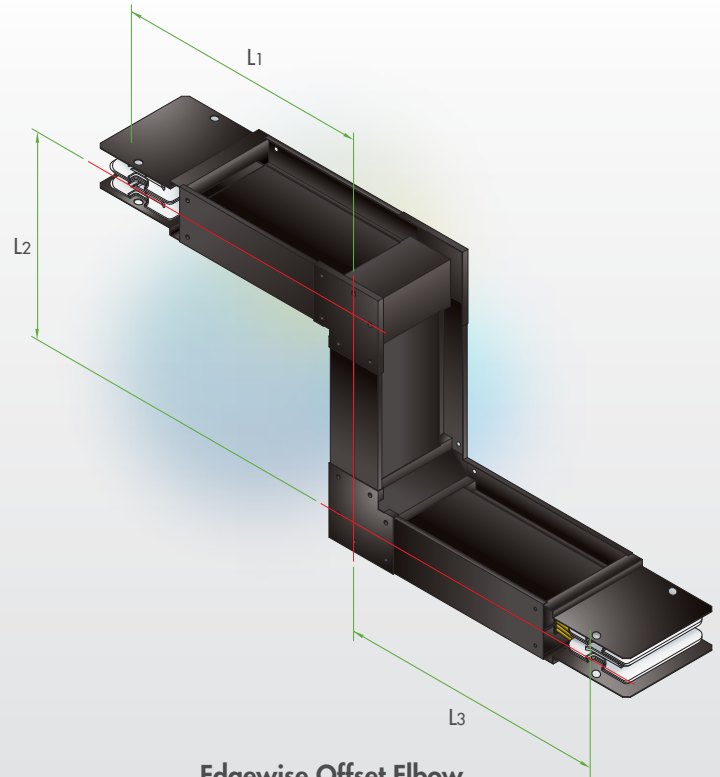

Edgewise Offset Elbow

Busduct Rating		Standard Length L1 x L2 x L3 (mm)	Standard Length L1 x L2 x L3 (mm)	Edgewise Offset	
Copper	Aluminium			Standard Length L1 x L2 x L3 (mm)	Minimum Length L1 x L2 x L3 (mm)
400A		400 x 500 x 400	320 x 280 x 320	400 x 400 x 400	290 x 220 x 290
600A	400A		320 x 280 x 320		
700A	500A		320 x 280 x 320		
800A			320 x 285 x 320		
	700A		325 x 290 x 325		
1000A			330 x 300 x 330		
1250A	800A		335 x 315 x 335		
	1000A		350 x 240 x 350		
1600A			355 x 350 x 355		
1800A	1300A		360 x 365 x 360		
2000A	1500A		375 x 390 x 375		
2200A	1600A		385 x 415 x 385		
2500A	1800A		400 x 440 x 400		
	2200A		420 x 480 x 420		
3000A		600 x 500 x 600	445 x 350 x 445	400 x 400 x 400	290 x 220 x 290
3500A	2500A		460 x 365 x 460		
4000A	3000A		485 x 390 x 485		
4500A	3200A		510 x 415 x 510		
5000A	3500A		535 x 440 x 535		
	4000A		575 x 480 x 575		
	4500A		600 x 390 x 600		
6300A			750 x 500 x 750		
	5000A	650 x 425 x 650			
	6000A	735 x 480 x 735			

Maximum length of offset elbow (L1 + L2 + L3) is 2500mm

Note : The above busduct length is designed for IP42 and IP65 Busduct system. The details of IP66 and weather shield design can be requested from Furutec Electrical.

PHYSICAL DATA

Combination Elbow

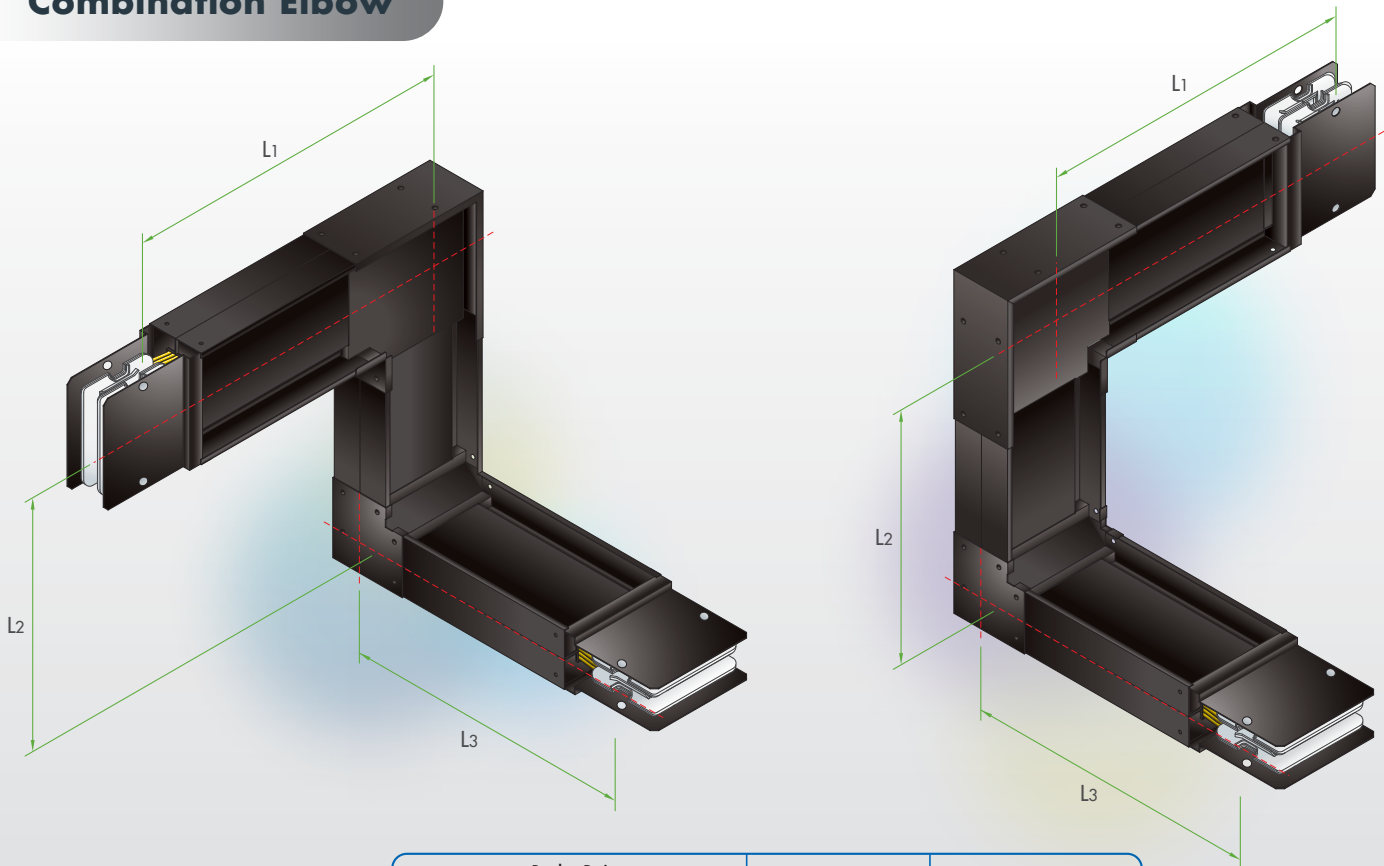

Busduct Rating		Standard Lengths L1 x L2 x L3 (mm)	Minimum Lengths L1 x L2 x L3 (mm)
Copper	Aluminium		
400A		400 x 400 X 400	320 x 255 x 290
600A	400A		320 x 255 x 290
700A	500A		320 x 255 x 290
800A			320 x 255 x 290
	700A		325 x 260 x 290
1000A			330 x 265 x 290
1250A	800A		335 x 270 x 290
	1000A		350 x 285 x 290
1600A			355 x 290 x 290
1800A	1300A		360 x 295 x 290
2000A	1500A		375 x 310 x 290
2200A	1600A		385 x 320 x 290
2500A	1800A		400 x 335 x 290
	2200A		420 x 355 x 290
3000A		600 x 600 x 600	445 x 380 x 290
3500A	2500A		460 x 395 x 290
4000A	3000A		485 x 420 x 290
4500A	3200A		510 x 445 x 290
5000A	3500A		535 x 470 x 290
	4000A		575 x 510 x 290
	4500A		600 x 535 x 290
6300A			750 x 750 x 750
	5000A	650 x 585 x 290	
	6000A	735 x 670 x 290	

Note : Maximum length of combination elbow (L1 + L2 + L3) is 2500mm

Note : The above busduct length is designed for IP42 and IP65 Busduct system. The details of IP66 and weather shield design can be requested from Furtec Electrical.

Elbow with Flange End / Flange End Box

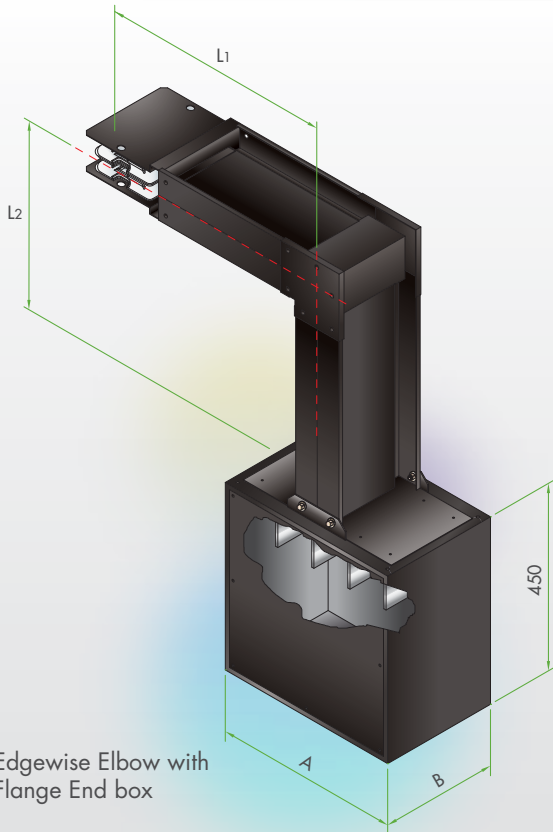

Edgewise Elbow with Flange End box

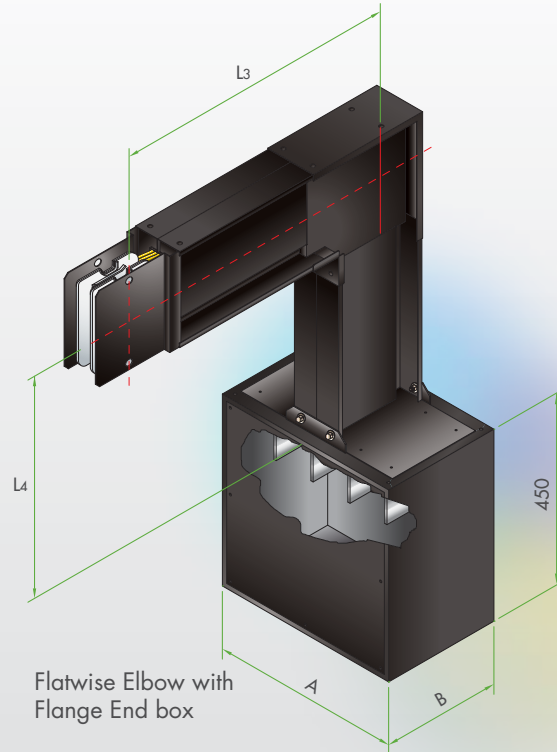

Flatwise Elbow with Flange End box

Busduct Rating		Standard Length (mm)				Minimum Length (mm)			
Copper	Aluminium	L ₁	L ₂	L ₃	L ₄	L ₁	L ₂	L ₃	L ₄
400A		400	400	400	400	290	290	320	205
600A	400A							320	205
700A	500A							320	205
800A								320	205
	700A							325	210
1000A								330	215
1250A	800A							335	220
	1000A							350	235
1600A								355	240
1800A	1300A							360	245
2000A	1500A			375	260				
2200A	1600A			385	270				
2500A	1800A			400	285				
	2200A			420	305				
3000A				445	330				
3500A	2500A			460	345				
4000A	3000A			485	370				
4500A	3200A			510	395				
5000A	3500A			535	420				
	4000A			575	460				
	4500A	600	485						
6300A		635	520						
	5000A	650	535						
	6000A	735	620						
			750	650					

Refer to page 12 and 13 for dimensions of A and B

Note :
The above busduct length is designed for IP42 and IP65 Busduct system. The details of IP66 and weather shield design can be requested from Furutec Electrical.

End Cap / End Closure

End Closure

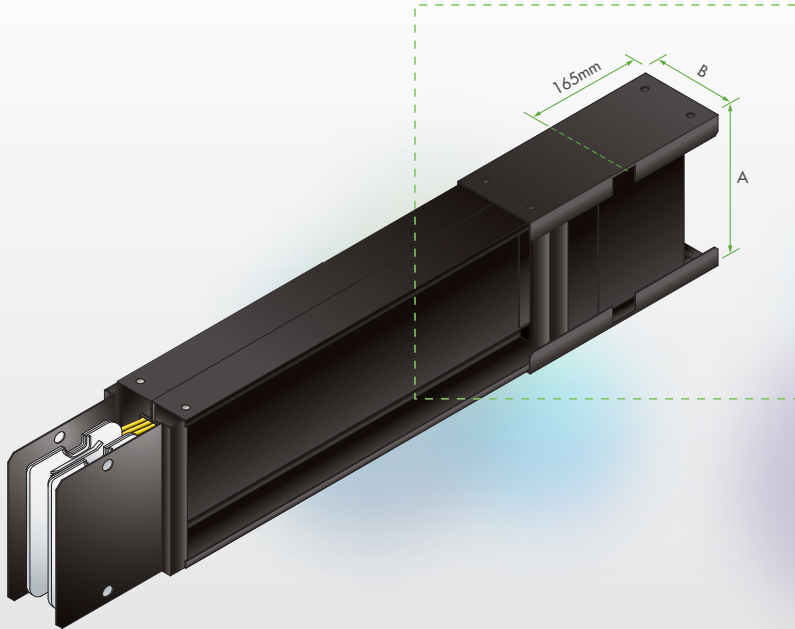

End Cap

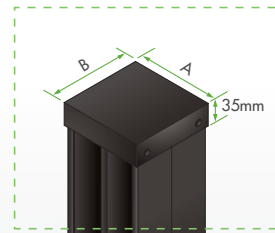

Busduct Rating		A (mm)	B (mm)	
Copper	Aluminium	3P3W 3P4W 3P4W+E 3P5W	3P3W	3P4W 3P4W+E 3P5W
400A		115	100	120
600A	400A	115		
700A	500A	115		
800A		120		
	700A	125		
1000A		135		
1250A	800A	150		
	1000A	175		
1600A		185		
1800A	1300A	200		
2000A	1500A	225		
2200A	1600A	250		
2500A	1800A	275		
	2200A	315		
3000A		370		
3500A	2500A	400		
4000A	3000A	450		
4500A	3200A	500		
5000A	3500A	550		
	4000A	630		
	4500A	675		
6300A		750		
	5000A	780		
	6000A	945		

Vertical Spring Hanger / Vertical Hanger

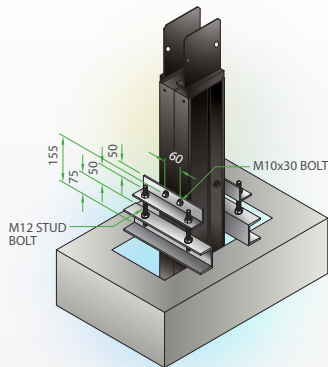

Vertical Hanger

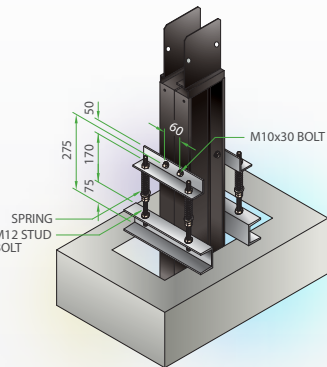

Vertical Spring Hanger

▲ 400A to 2500A Copper Busduct
400A to 2200A Aluminium Busduct

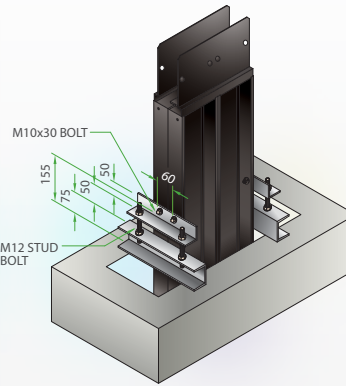

Vertical hanger

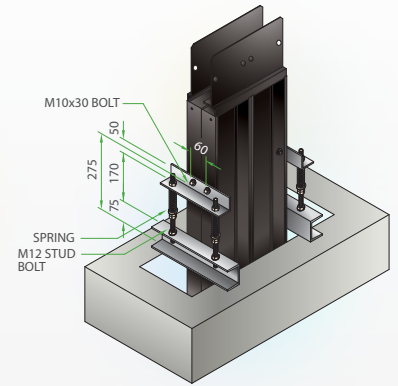

Vertical Spring Hanger

▲ 3000A to 3500A Copper Busduct
2500A to 4000A Aluminium Busduct

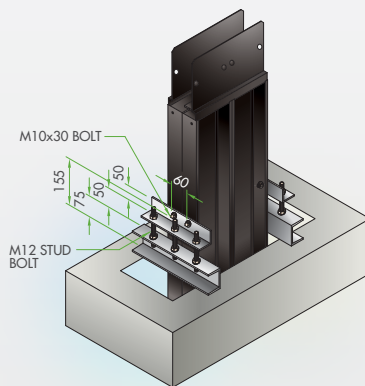

Vertical hanger

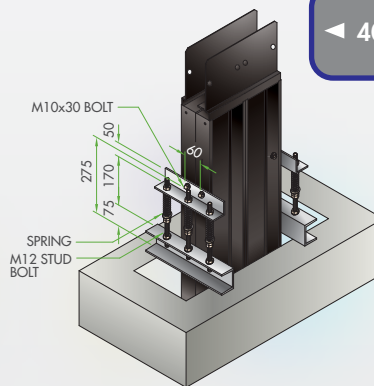

Vertical Spring Hanger

◀ 4000A to 5000A Copper Busduct

6300A Copper Busduct ▶
4500A to 6000A Aluminium Busduct

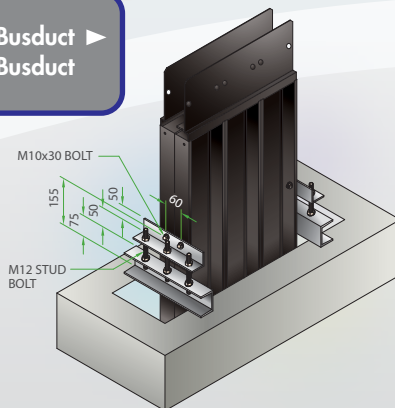

Vertical Hanger

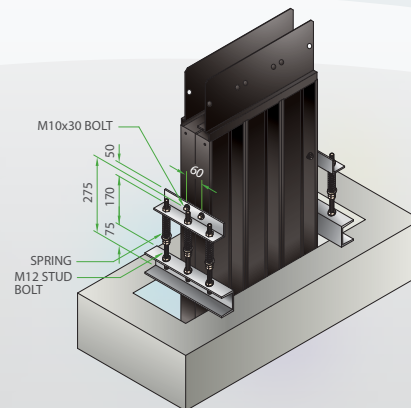

Vertical Spring Hanger

PHYSICAL DATA

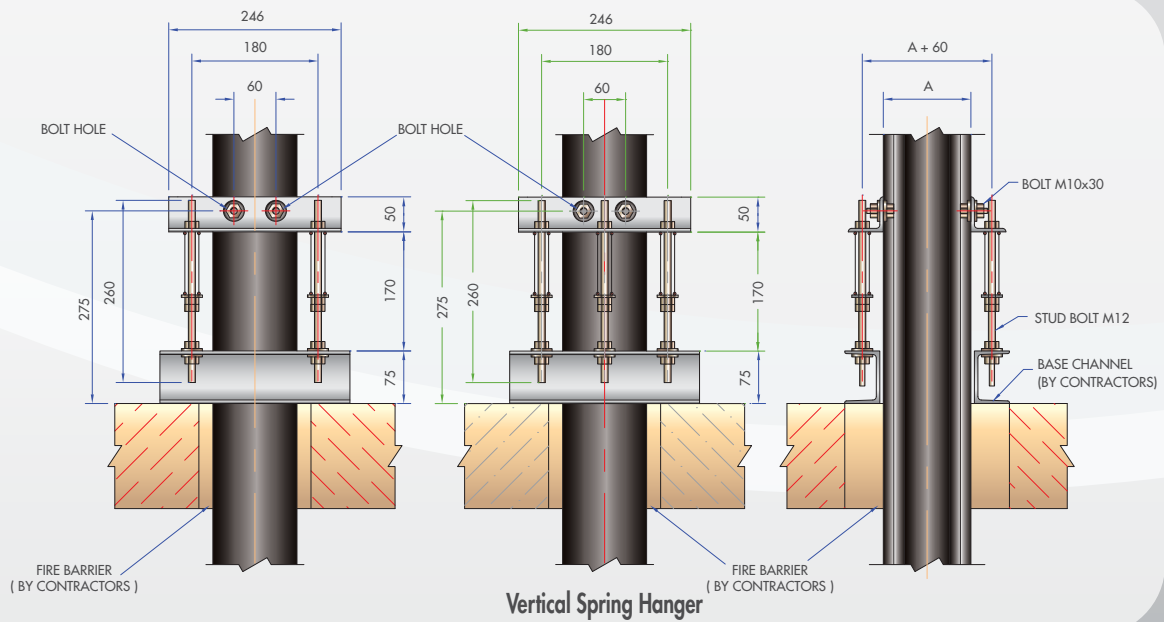
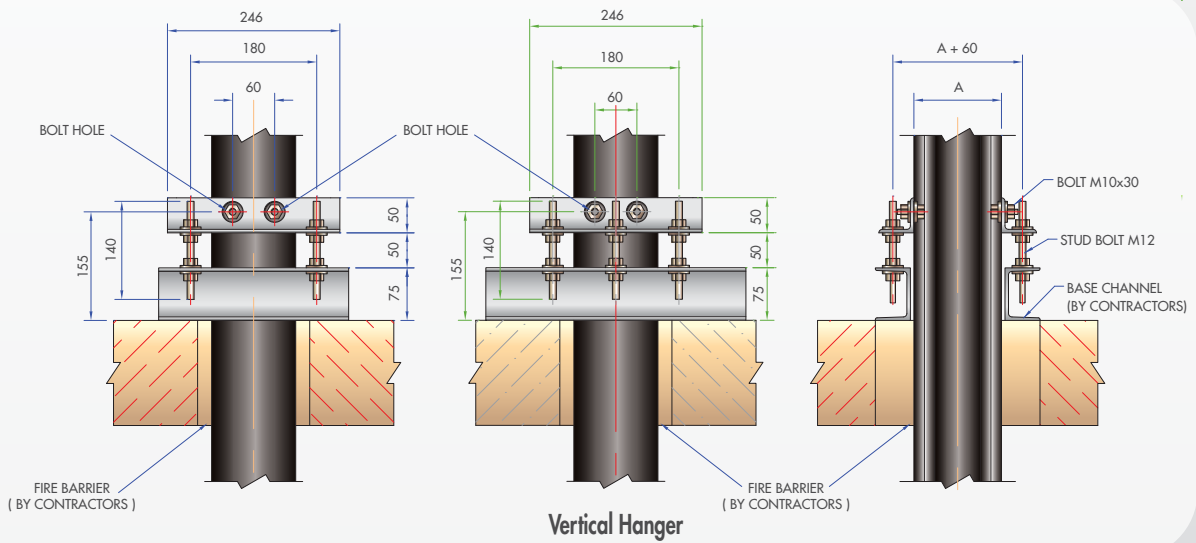
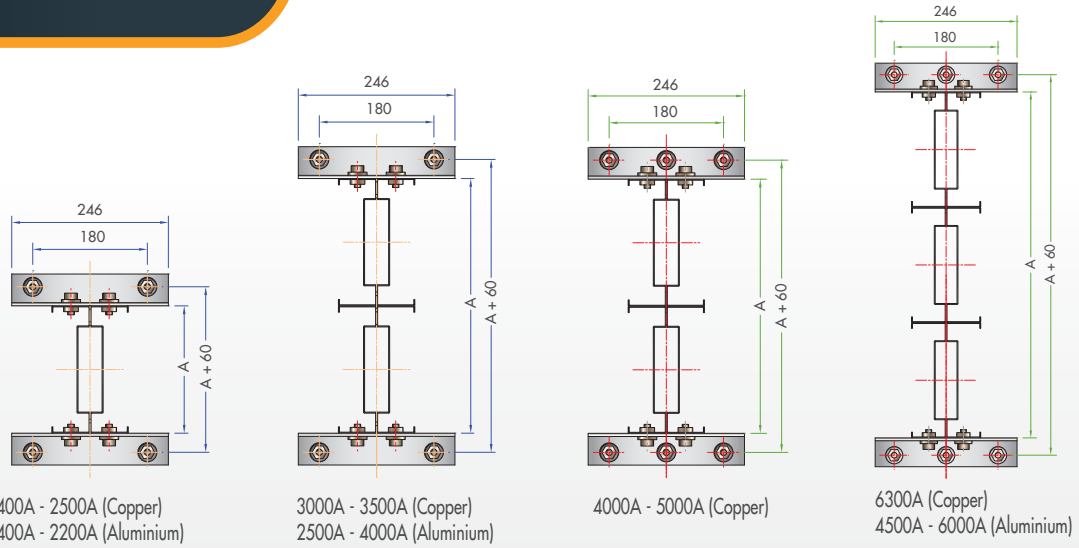

Refer to page 11 for the dimensions of A

Edgewise / Flatwise Hanger

Edgewise Hanger

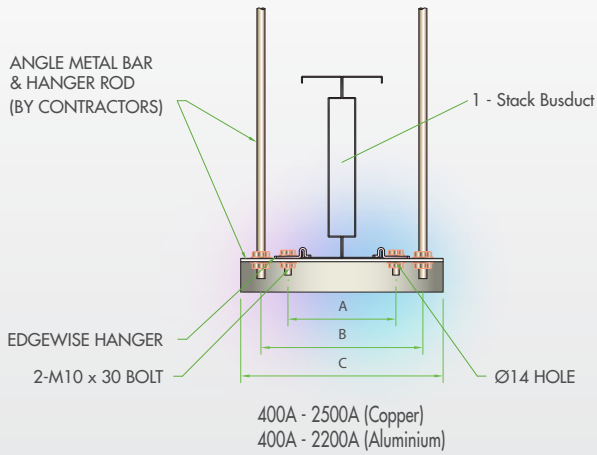

(Fig 1)

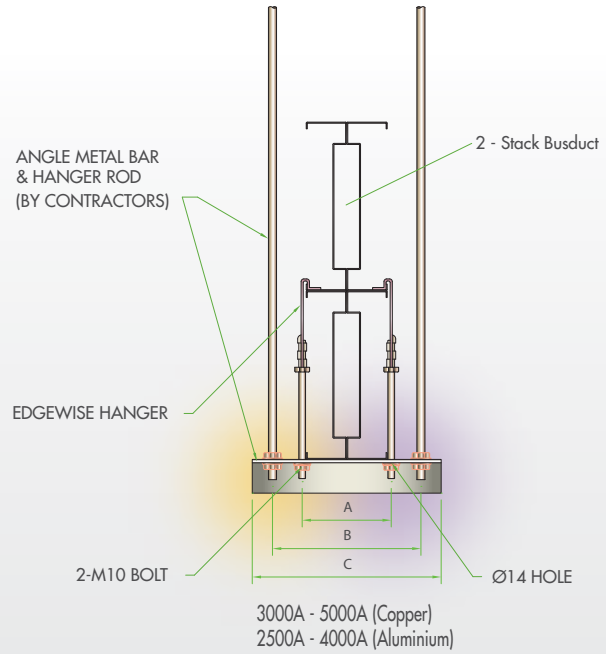

(Fig 2)

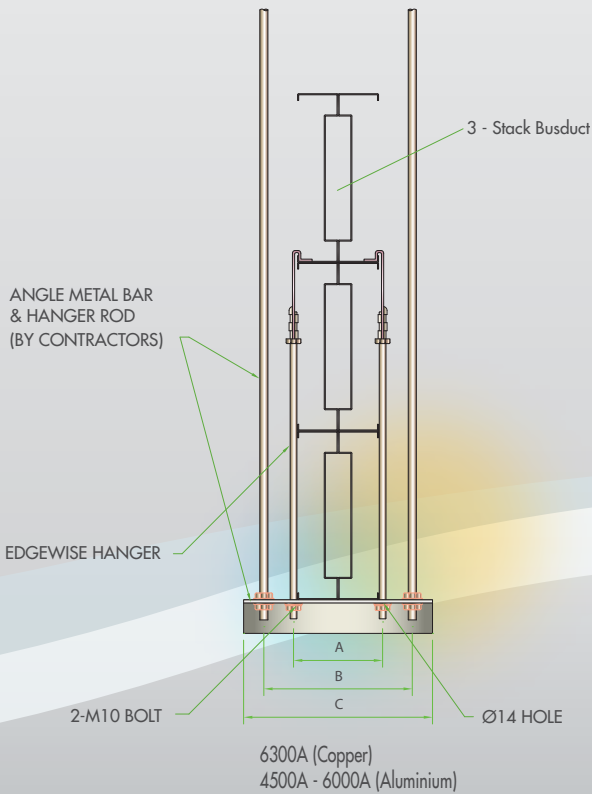

(Fig 3)

Busduct Rating		Fig	Dimension (mm)										
			A		B		C						
Copper	Aluminium		3P3W	3P4W 3P4W+E 3P5W	3P3W	3P4W 3P4W+E 3P5W	3P3W	3P4W 3P4W+E 3P5W					
400A		1	140	160	220	240	280	300					
600A	400A												
700A	500A												
800A													
	700A												
1000A													
1250A	800A												
	1000A												
1600A													
1800A	1300A												
2000A	1500A												
2200A	1600A												
2500A	1800A	2	112	132	220	280	280						
	2200A												
3000A													
3500A	2500A												
4000A	3000A												
4500A	3200A												
5000A	3500A												
	4000A												
	4500A												
6300A								3					
	5000A												
	6000A												

PHYSICAL DATA

Flatwise Hanger

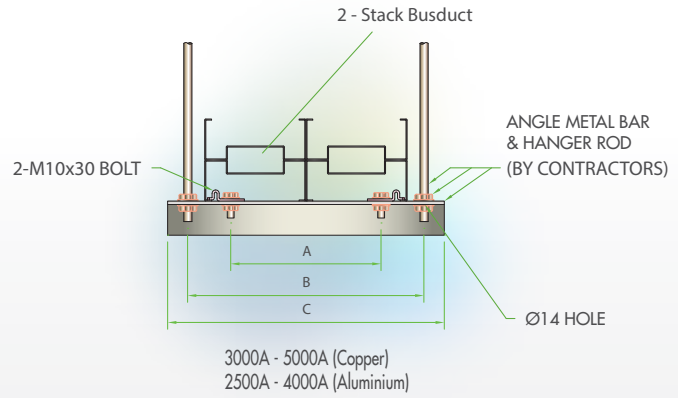
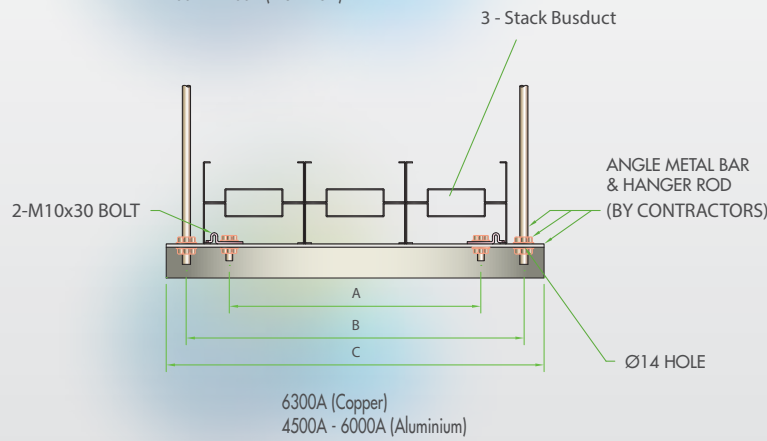
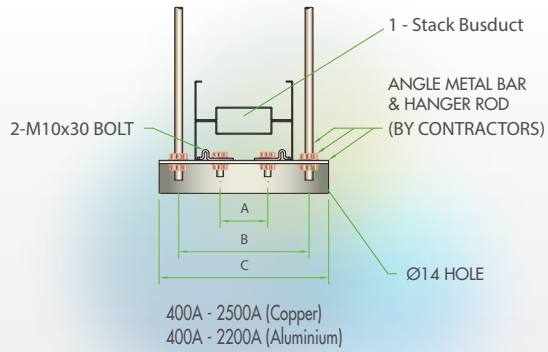

Busduct Rating		Dimension (mm)		
Copper	Aluminium	A	B	C
400A		38	165	225
600A	400A	38	165	225
700A	500A	38	165	225
800A		43	170	230
	700A	48	175	235
1000A		58	185	245
1250A	800A	73	200	260
	1000A	98	225	285
1600A		108	235	295
1800A	1300A	123	250	310
2000A	1500A	148	275	335
2200A	1600A	173	300	360
2500A	1800A	198	325	385
	2200A	238	365	425
3000A		293	420	480
3500A	2500A	323	450	510
4000A	3000A	373	500	560
4500A	3200A	423	550	610
5000A	3500A	473	600	660
	4000A	553	680	740
	4500A	598	725	785
6300A		673	800	860
	5000A	703	830	890
	6000A	868	995	1055

Reducer

Reducer is used to reduce busbar sizes to the final load. It provides users with more economic power transmission and distribution method. The minimum length (L) is 600mm and the reduction from a higher busduct rating to a lower busduct rating should not exceed 45%.

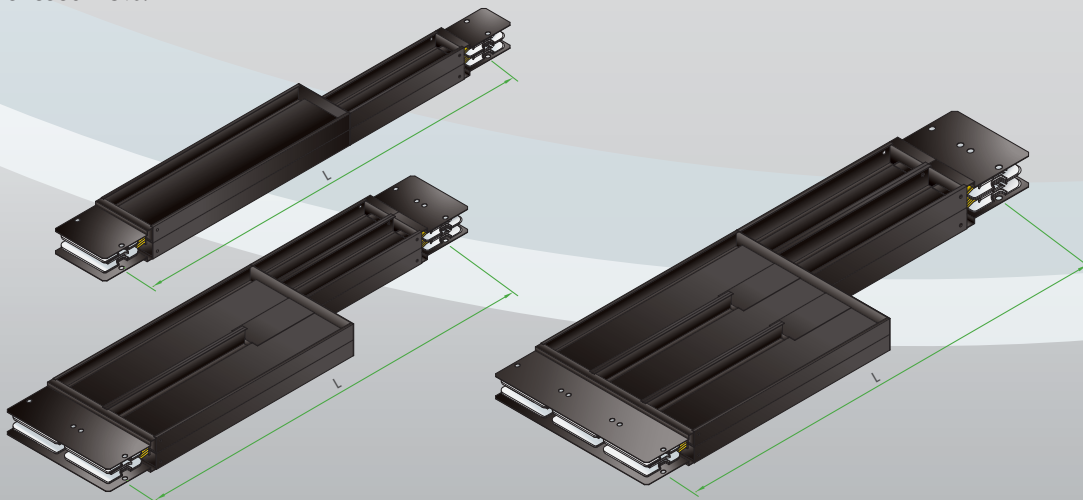

Remark: If the reduction is more than 45%, a protective device (e.g. circuit breaker) must be installed in between both busduct feeders.

PHYSICAL DATA

Expansion Unit

The busduct system expands and contracts when the electrical load and the ambient temperature vary. The expansion unit is the transition section compensating the thermal expansion and contraction. The requirement of expansion unit in a vertical installation is determined by the method of how both ends of busduct system are supported. The use of plug in hole and total length of vertical busduct are important factors of determining the requirement of expansion unit.

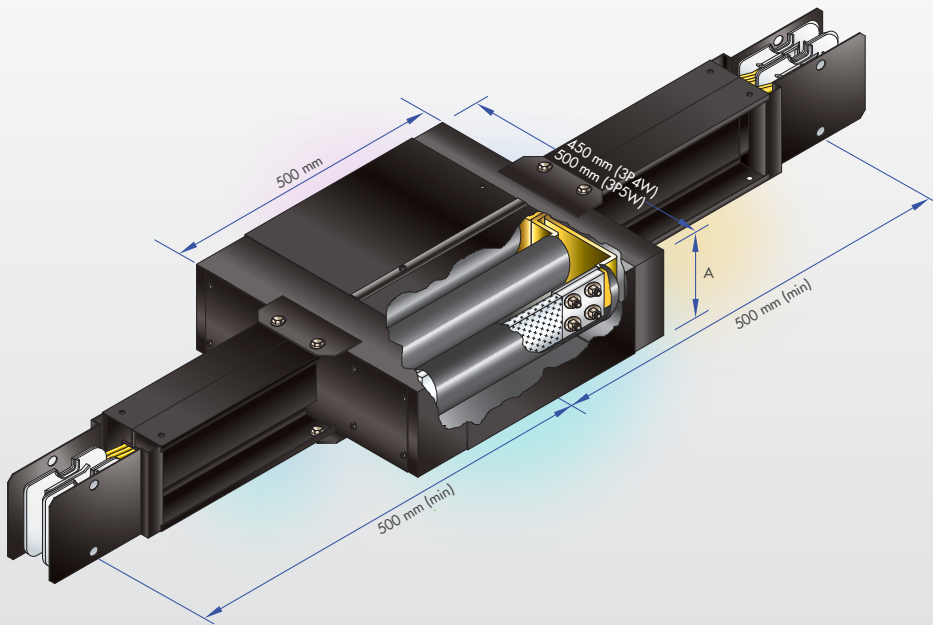

Busduct Rating		A (mm)
Copper	Aluminium	
400A		115
600A	400A	115
700A	500A	115
800A		120
	700A	125
1000A		135
1250A	800A	150
	1000A	175
1600A		185
1800A	1300A	200
2000A	1500A	225
2200A	1600A	250
2500A	1800A	275
	2200A	315
3000A		370
3500A	2500A	400
4000A	3000A	450
4500A	3200A	500
5000A	3500A	550
	4000A	630
	4500A	675
6300A		750
	5000A	780
	6000A	945

Supporting Condition	Use of Plug in hole	Fig.	Maximum Length (L) without expansion unit
Both ends free	Plug in hole on each floor	1	≤ 120 mtr
One end free	Plug in hole on each floor	2	≤ 90 mtr
One end fixed	No Plug in hole	3	≤ 30 mtr
Both ends fixed	Plug in hole on each floor	4	≤ 30 mtr
	No Plug in hole	5	≤ 15 mtr

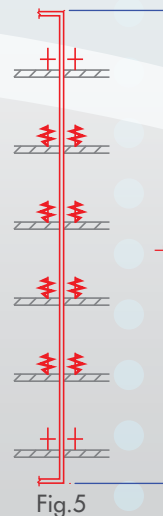
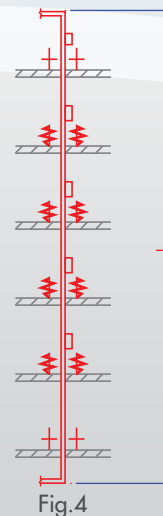
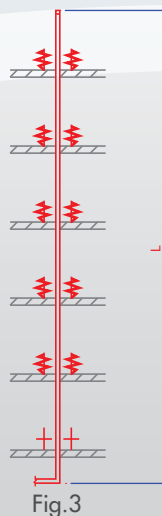
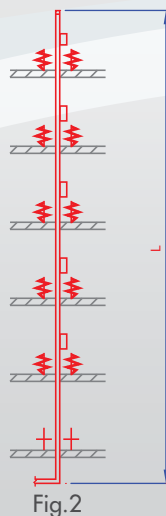
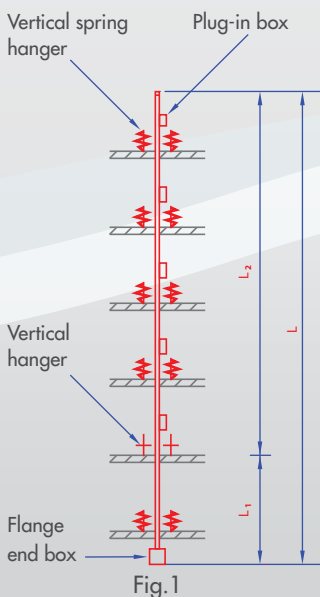

PHYSICAL DATA

Flexible Link

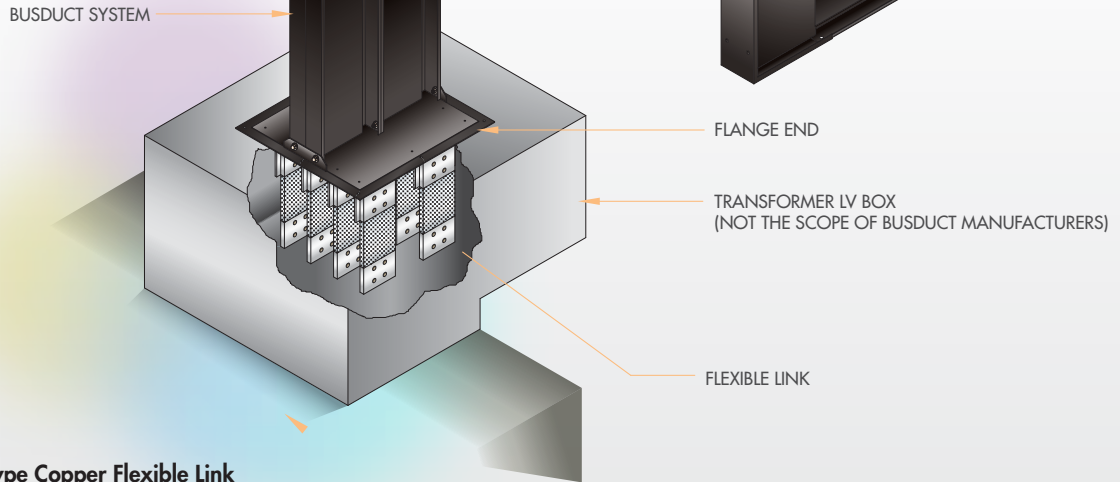

Dimension of Braided Type Copper Flexible Link

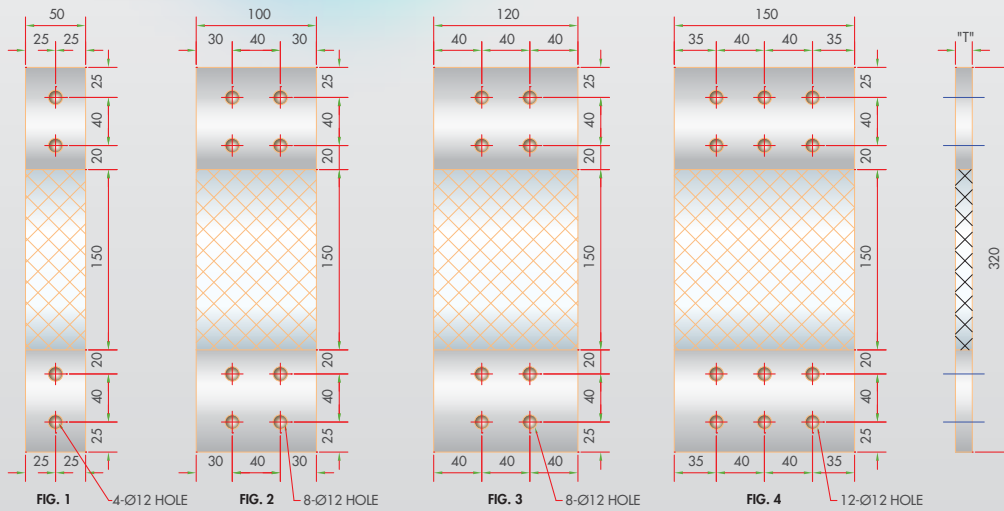

Copper Busduct :

Busduct Rating	Conductor Size per Phase (mm)	Fig	Model	Dimension "T" (mm)
400A	One - 6 x 20	1	F5013 x 1	13
600A	One - 6 x 30			
700A	One - 6 x 40			
800A	One - 6 x 45			
1000A	One - 6 x 60	2	F5013 x 2	13
1250A	One - 6 x 75			
1600A	One - 6 x 110	3	F12014 x 1	14
1800A	One - 6 x 125			
2000A	One - 6 x 150	4	F15014 x 1	14.5
2200A	One - 6 x 175		F15016 x 1	16
2500A	One - 6 x 200		F15017 x 1	17.5
3000A	Two - 6 x 110	3	F12014 x 2	14
3500A	Two - 6 x 125		F15014 x 2	14.5
4000A	Two - 6 x 150	4	F15016 x 2	16
4500A	Two - 6 x 175		F15017 x 2	17.5
5000A	Two - 6 x 200		F15017 x 3	17.5
6300A	Three - 6 x 175			

Aluminium Busduct :

Busduct Rating	Conductor Size per Phase (mm)	Fig	Model	Dimension "T" (mm)
400A	One - 6 x 30	1	F5013 x 1	13
500A	One - 6 x 40			
700A	One - 6 x 50			
800A	One - 6 x 75			
1000A	One - 6 x 100	2	F10013 x 1	13
1300A	One - 6 x 125			
1500A	One - 6 x 150	3	F12014 x 1	14
1600A	One - 6 x 175			
1800A	One - 6 x 200	4	F15016 x 1	16
2200A	One - 6 x 240			
2500A	Two - 6 x 125			
3000A	Two - 6 x 150	3	F12014 x 2	14
3200A	Two - 6 x 175			
3500A	Two - 6 x 200	4	F15014 x 2	14.5
4000A	Two - 6 x 240			
4500A	Three - 6 x 150			
5000A	Three - 6 x 185	4	F15016 x 3	16
6000A	Three - 6 x 240		F15017 x 3	17.5

Tap Off Unit

Plug-In Box & Plug-In Hole

Plug in box is mechanically interlocked with the busduct housing to prevent installation or removal while the MCCB is in 'ON' position. It is equipped with an operating handle to control the switching mechanism. The plug in box makes positive ground connection to the busduct housing before making contact to the phase conductors.

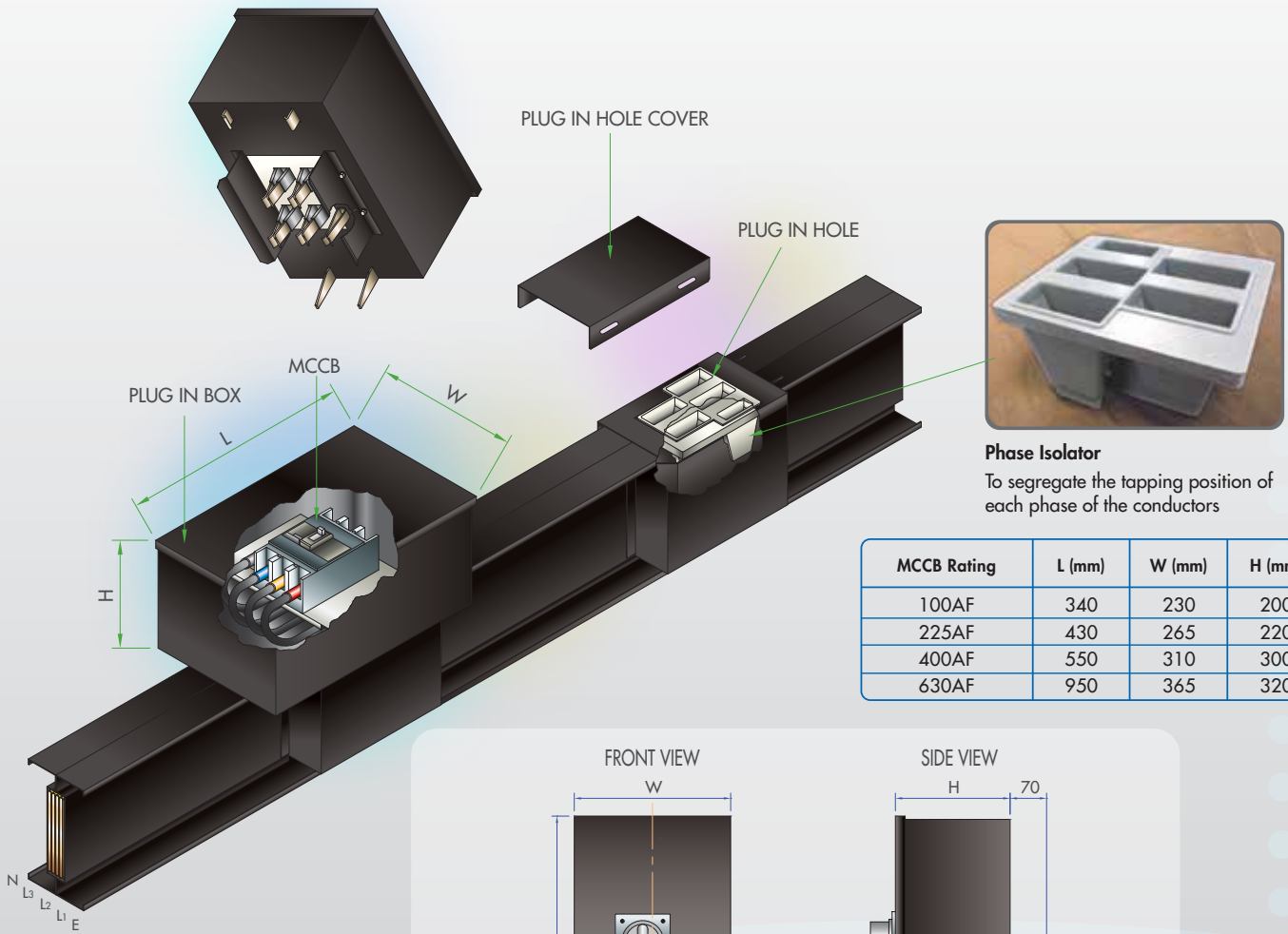

Phase Isolator
To segregate the tapping position of each phase of the conductors

MCCB Rating	L (mm)	W (mm)	H (mm)
100AF	340	230	200
225AF	430	265	220
400AF	550	310	300
630AF	950	365	320

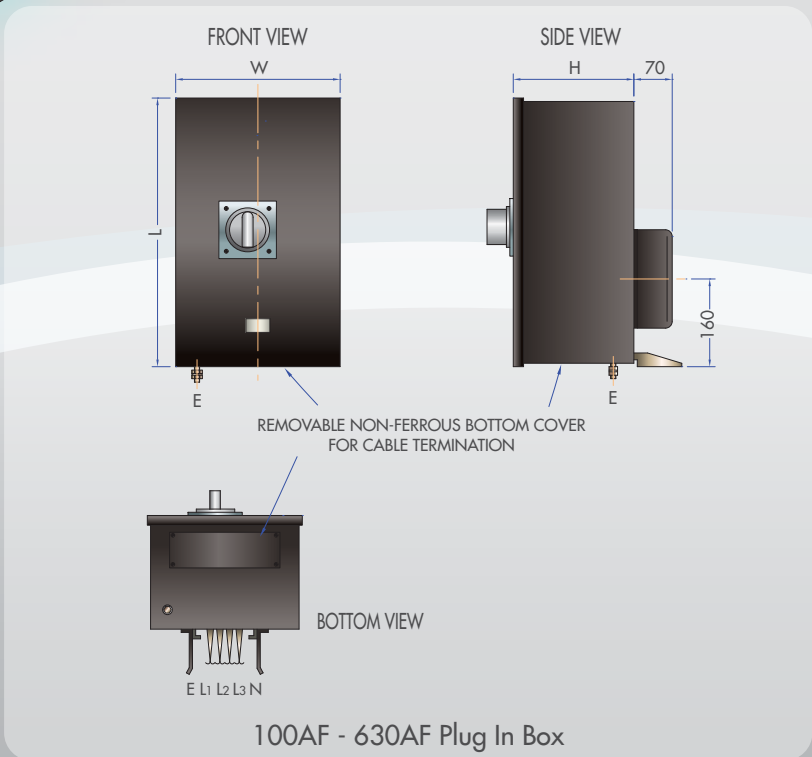

Tap Box & Tap Bar

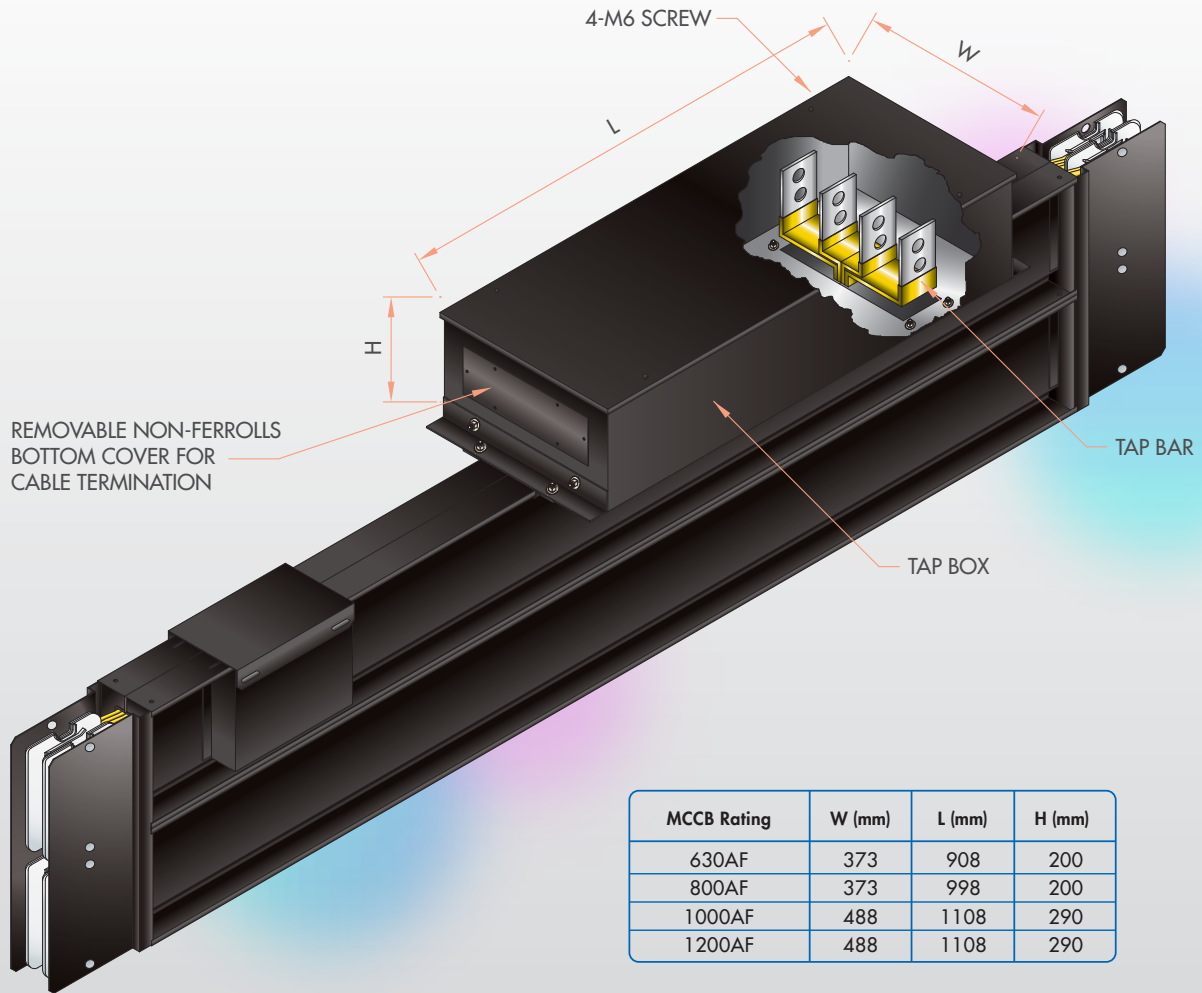

MCCB Rating	W (mm)	L (mm)	H (mm)
630AF	373	908	200
800AF	373	998	200
1000AF	488	1108	290
1200AF	488	1108	290

Note : Customized plug in type 800AF, 1000AF & 1200AF tap-off units are available upon request.

DESIGN FACTORS

1. Minimum Distance Between Parallel-Installed Busduct System.

1.1 Edgewise Installation (IP42, IP65)

Busduct joints installed side by side.

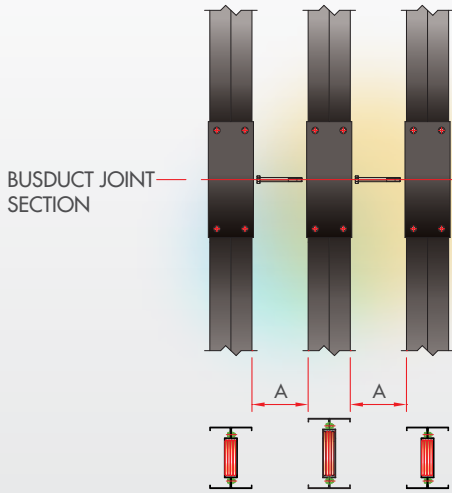

Busduct joints installed deviating from each other (Dimension "C" is above 190mm).

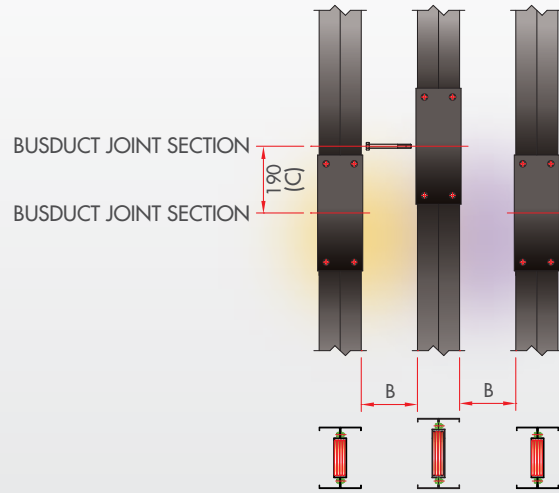

Busduct Rating	Dimension "A" (mm)		Dimension "B" (mm)	
	3P3W	3P4W/3P5W	3P3W	3P4W/3P5W
400A - 6300A	150	160	85	95

1.2 Edgewise Installation (IP66)

Busduct joints installed side by side.

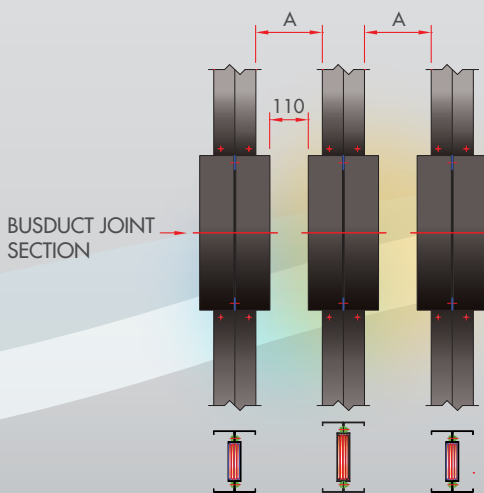

Busduct joints installed deviating from each other (Dimension "C" is above 500mm).

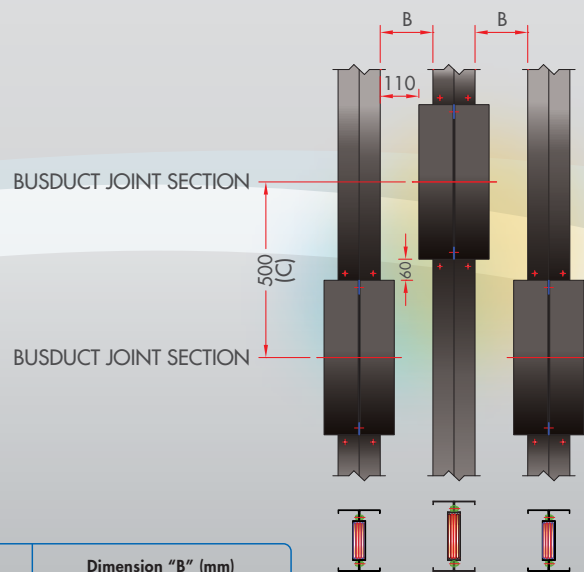

Busduct Rating	Dimension "A" (mm)		Dimension "B" (mm)	
	3P3W	3P4W/3P5W	3P3W	3P4W/3P5W
400A - 6300A	170	190	130	150

DESIGN FACTORS

1.3 Flatwise Installation

Minimum clearance for busduct installed in flatwise position.

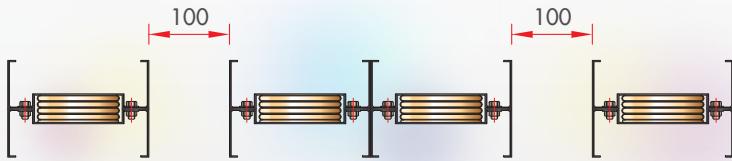

1.4 Plug-in Type Busduct Installation.

Minimum clearance for plug-in type busduct installed in parallel.

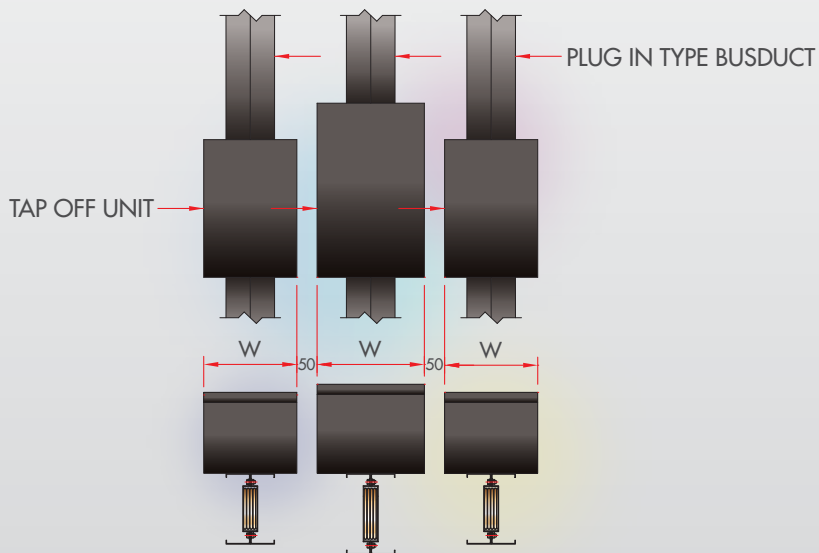

2. Minimum Clearance between busduct and wall, floor, etc.

2.1 Ceiling and Wall.

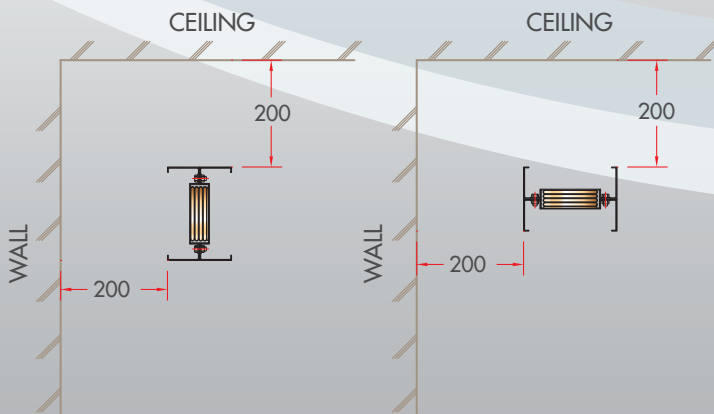

2.2 Beam.

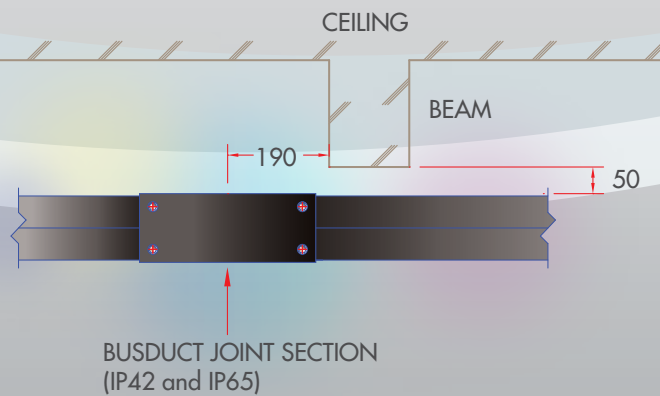

2.3 Distance between busduct joint section and wall surface for wall penetration

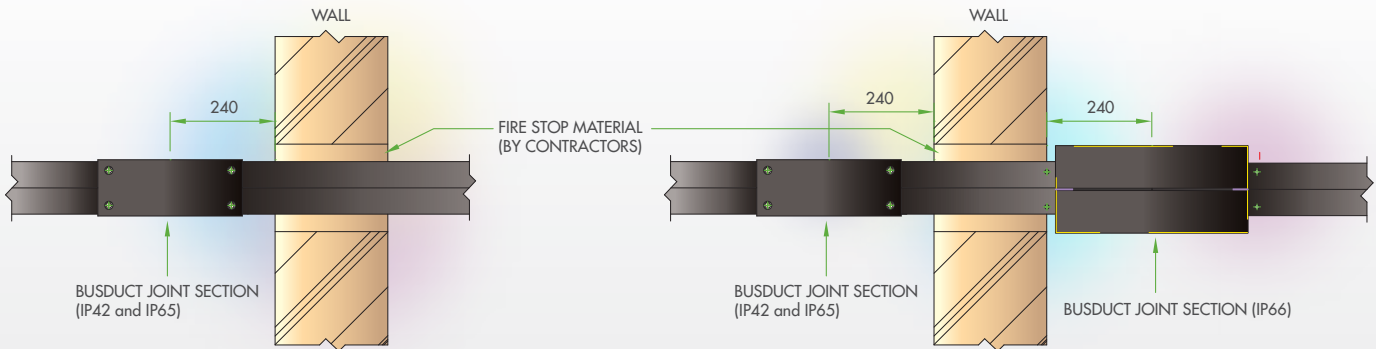

2.3 Distance between busduct joint section and floor/ceiling surface for floor penetration

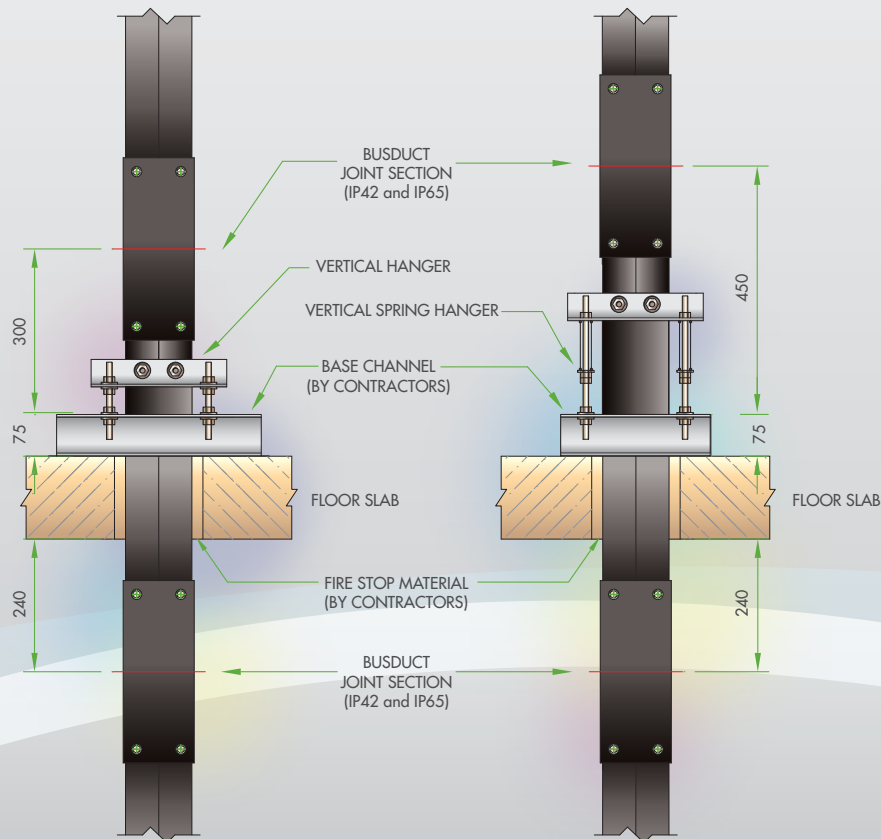

Busduct joints must not be installed in between the wall and floor. The busduct joints shall be at least 240mm from the ceiling surface. If vertical spring hanger is installed on the floor, the distance between busduct joint and base channel shall be at least 450mm. If vertical hanger is installed on the floor, the distance between busduct joint and base channel shall be at least 300mm. The height of base channel is recommended to be 75mm.

INSTALLATION & MAINTENANCE PROCEDURE

Before Busduct Installation

1. When the busduct arrives at project site, check the type and quantity of busduct feeders and accessories from delivery order. Inspect for physical damages caused during transportation and unloading.
2. Keep the busduct in a dry place, away from water and moisture, preferably under a roof protected from rain. Cover the busduct with water-proof material if necessary.
3. Do not lay the busduct directly onto the ground or in an upright position. Always place pieces of wood under the busduct and stack up firmly.
4. For long periods of storage, ensure that the busduct is placed in a dry place free from condensation.

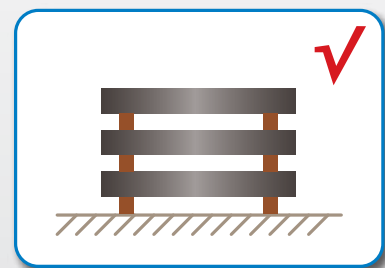
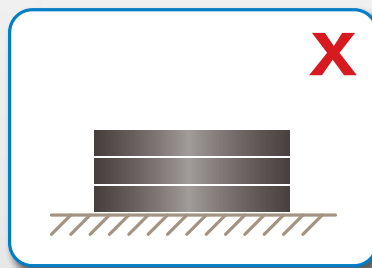
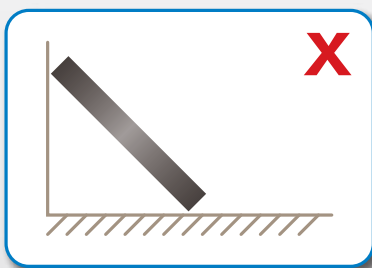

5. To prevent the busduct joint from being soiled, wrap both busduct ends with water-proof material while unpacking. Before busduct joint installation, examine the conductor contact surface or insulation materials for any damages. It is important to ensure that the joint sections are not soiled with dust, dirt and other foreign matter.
6. Sufficiently strong materials and equipment must be used during handling and lifting to reduce the risk of personal injury and equipment damage at site. Busduct must be handled with care to avoid damage to internal components and metal housing.
7. During unloading, do not drop it or let it hit with other objects. Do not drag busduct across the floor or across other busduct sections. A fork lift may provide a more convenient method of handling and has the added advantage of permitting it to be lifted between levels.
8. Platform/Scissor lifts or elevators, either manually or power operated, can be used advantageously in moving the busduct between elevations. Remember to check that the total weight of personnel plus busduct is within the capacity of the lift/ elevator.
9. If a crane is used to move the busduct, use nylon straps and distribute the weight on each lift. If rope is used, insert thick pieces of rag, foam or corrugated cardboard between them to prevent the busduct from being damaged/scratched. Do not place slings, rope or chains around the busduct ends since damage can easily occur. For busduct rated 2500A and above, pieces of strong wood should be used when rope is applied, in order to prevent the busduct housing from being deformed.
10. If a fork lift or similar hoist is used, properly position the busduct on the fork to distribute its weight. Careful approach is a must to avoid any damage to the metal housing that would break the phase isolators (ISP) at busduct joint.
11. While installing vertical busduct, it may be easier to lower the busduct feeder from one floor above where it will be installed. The busduct feeders are usually stored on the floor above their final location to facilitate lowering them into position. Protect both busduct ends when rising from horizontal to vertical positions.
12. When the installation work is suspended or halted at job site, the end section of the connecting busduct feeders should be protected against water and dust by covering them with polythene or other appropriate materials.

INSTALLATION & MAINTENANCE PROCEDURE

During Busduct Installation

1. In vertical busduct installation, busduct feeder which will be supported by vertical hanger should be installed before other busduct feeders in order to prevent a downward weight or load from concentrating on the busduct at the lower floor.
2. Flange end box must not be fixed permanently to the wall and floor. However, flange end box can only be permanently secured provided that all the busduct installations are completed (if unavoidable).
3. Vertical hanger/vertical spring hanger must be installed to the busduct system to allow for busduct elongation/expansion & contraction as well as the shrinkage of the building.
4. Waterproof curb is recommended to be installed at each floor opening where the busduct passes through. It prevents water (caused by plumbing leaks, fire sprinkler system leaks, fluid spills, etc) from seeping into the busduct system. Additionally, the floor opening should be sealed with fire stop material to prevent fire from passing through the floors in case of fire in the building.

Busduct Joint

1



Determine the male and female sides of the busduct feeders to be connected.

2



Align the busduct feeders end to end.

3



Align the leaf springs so that the high tensile bolts can be fitted through the busduct housing.

4



Tighten the two bolts alternately to ensure even distribution of force is applied to the busduct joint. **Tighten them until the leaf springs become almost flat and until the snap-pin-hole on the high tensile bolt is visible.**

5

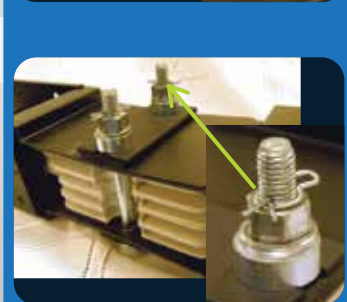

Insert the snap pins into the pin holes.

6



Cover the busduct joint section with joint covers on both sides. The installation is complete.

INSTALLATION & MAINTENANCE PROCEDURE

Tap Off Unit (Plug In Type)

1



Check the drawings to identify the location of tap-off units to be installed.

2



Plug In Hole Cover

Remove the cover of each plug-in hole.



Plug In Hole

3



Ensure that the MCCB handle is in 'OFF' position.

4



Earth Jaw

By using the earth jaw of the plug-in box as a guideline, the earth jaw must be fully inserted before pushing the plug-in clip into the plug-in hole of the busduct system.



5

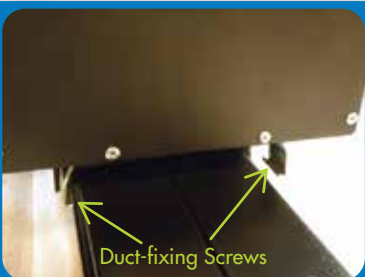

Duct-fixing Screws

Open the front cover of the plug in box. Fasten the duct-fixing screws in the box to firmly attach the plug in box to the busduct.



6



Terminate cables to the outgoing terminal of MCCB and insert internal barriers (perspex) to prevent accidental contact with the live parts at the terminals of MCCB. The installation is complete.

Tap-off units shall make positive ground connection with busduct housing or earth conductors before making contact with the phase conductors.



Make sure that the MCCB is in 'OFF' position before carrying out any live installation works of tap-off unit to the plug in holes of busduct system.

INSTALLATION & MAINTENANCE PROCEDURE

Tap-off Unit (Bolt-on Type)

1. Check the drawings to identify the location of tap bar where the tap box shall be installed.
2. Open the front cover of the tap box and insert the tap bar through the opening of the tap box and fix the box to the tap bar flange by fastening the screws.
3. Connect the copper link bar (from the incoming terminal of MCCB) to the tap bar. For Aluminium busduct, bi-metal plate shall be inserted in between the copper link bar and tap bar.
4. The tap box shall be firmly fixed to the busduct by using flat hanging clamp at each corner of tap box.
5. Close the front door of the tap box after terminating cables to the outgoing terminal of MCCB.

Vertical Spring Hanger / Vertical Hanger

1. Drill 4 nos bolt holes of $\text{Ø}12\text{mm}$ on the housing of the vertical busduct.
2. Install the vertical hanger and fix to the busduct tightly.
3. Connect the busduct in sequence and install the vertical spring hangers to each floor accordingly.

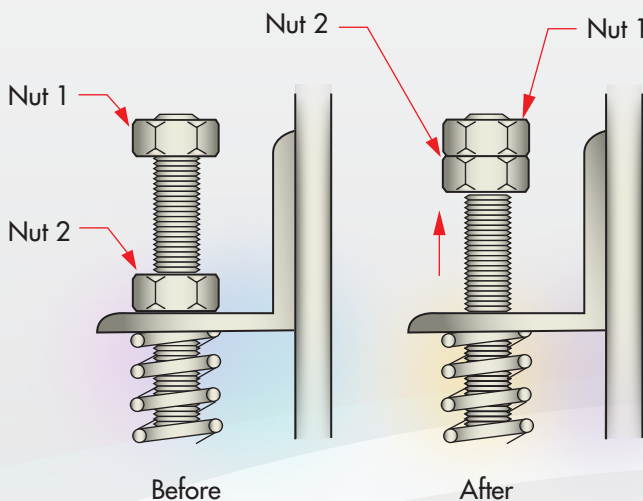

After the installation, Nut 2 must be moved towards Nut 1 and both nuts must be tightened together.

Vertical Spring Hanger

Refer to the details of dimension of vertical spring hanger and vertical hanger on page 20 and 21



Vertical Spring Hanger (front view)



Vertical Spring Hanger (side view)

INSTALLATION & MAINTENANCE PROCEDURE

Edgewise / Flatwise Hangers

1. Prepare the angle metal bars and hanger rods prior to the installation of horizontal busduct.
2. Hang the hanger rods from the ceiling and attach the angle metal bar at the height of the busduct to be laid.
3. The edgewise / flatwise hangers should be installed in every interval of at least 1500mm (1.5m) including the busduct elbows.

Refer to the details of Edgewise / Flatwise Hanger on page 22 and 23

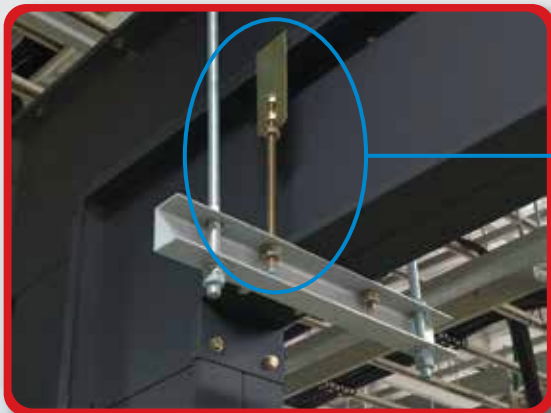
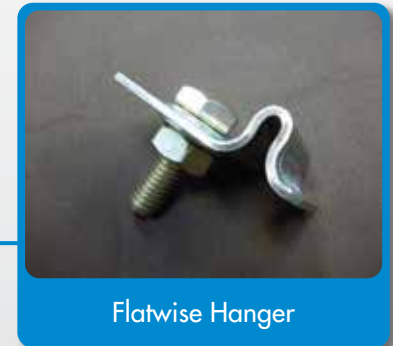
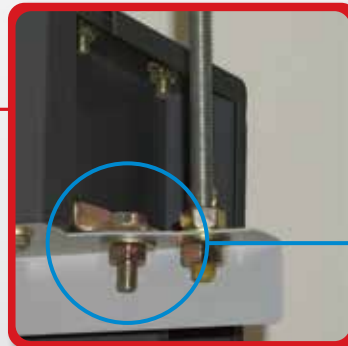

Connection with Equipment

Flange end / flange end box is used for cable or busbar termination. Where connections are to be made to a switchboard or transformer, the phase sequence of transformer and switchboard shall be coordinated and matched before busduct fabrication and installation works. Braided type of copper flexible link bars are connected between busduct flange end and LV terminals of transformer.

For vertical busduct installed in the electrical riser room, the flange end box must not be fixed permanently to the wall and floor. However, the flange end box can only be permanently secured provided that all the busduct installation works are completed (if unavoidable).

INSTALLATION & MAINTENANCE PROCEDURE

After Busduct Installation

1. After the completion of busduct installation at project site, it is advisable to carry out a thorough inspection of the whole busduct route, followed by measurement of insulation resistance / Megger.
2. Before conducting the measurement of insulation resistance, all the equipment connected to busduct system should be disconnected and MCCB rotary handle of tap-off units should be in 'OFF' position.
3. The insulation resistance value cannot be specified due to different length of the busduct and environmental condition. But if it is installed in a dry atmosphere, the value of resistance should be approximately 100 M Ω (500V Megger).
4. The following inspection procedures should be carried out. Determine whether:-
 - 4.1) The busduct feeders are physically damaged.
 - 4.2) All the connecting parts are fixed precisely (e.g. flange end box, tap-off units, etc).
 - 4.3) The bolts for connecting the equipment are securely fastened.
 - 4.4) The busduct joint are tightened in accordance to Furutec's requirement and recommendation.
 - 4.5) The busduct is supported securely by the hangers.
 - 4.6) Conduct thermal scanning test on busduct housing, joint section and other connections to detect any abnormal heat or hot spot

Recommended Maintenance Procedures

The following maintenance procedures and periodical inspection are recommended to ensure a safe operation of busduct system for long terms.

1. Period of Inspection

An inspection on busduct once a year or once every two years is recommended. If busduct system is installed in unfavourable conditions such as, temperature and/or humidity is high, there is a lot of dust or in similar environment, the periodical inspection must be conducted.

In the event of the following unusual conditions, inspection must be carried out immediately in each case:

- a.) After severe earthquake
- b.) After a fire has occurred
- c.) After being exposed to water
- d.) After an electrical fault

2. Maintenance and Routine Inspection

2.1 Inspection on External Appearance

Check whether :-

- ✓ There is any deformation, damage, dirt, etc throughout the whole length of busduct systems
- ✓ There is any dislocation, bending and other abnormality of the connecting covers, hangers and plug-in appliances

2.2 Environmental Inspection

The environment, where the busducts are installed, could change after its installation. Check whether the environment has become hazardous due to water, moisture, high temperature, corrosive gas, immoderate vibration, dust, etc.

INSTALLATION & MAINTENANCE PROCEDURE

2.3 Inspection for Abnormal Heat

An Infra Red Thermography instrument is recommended to detect any abnormal heat and measure the operating temperature of busduct system.

As an option, a thermal indicator can be placed onto the busduct housing. If the temperature rise of the busduct housing exceeds the limit, the colour of the indicator will change.

2.4 Inspection on Connection Sections

Check whether:-

- ✓ Busduct joint section is securely fastened with **joint bolts** and both sides of the busduct joint section are held with a pair of **leaf springs**.
- ✓ Leaf springs are almost flat and the pin holes are inserted with snap pins.
- ✓ Busduct is supported by vertical spring hangers, vertical hangers, edgewise / flatwise horizontal hangers according to manufacturer's requirement and recommendation.
- ✓ All the connecting parts, such as leaf springs, hangers, busduct joints, joint covers, etc are fixed precisely.

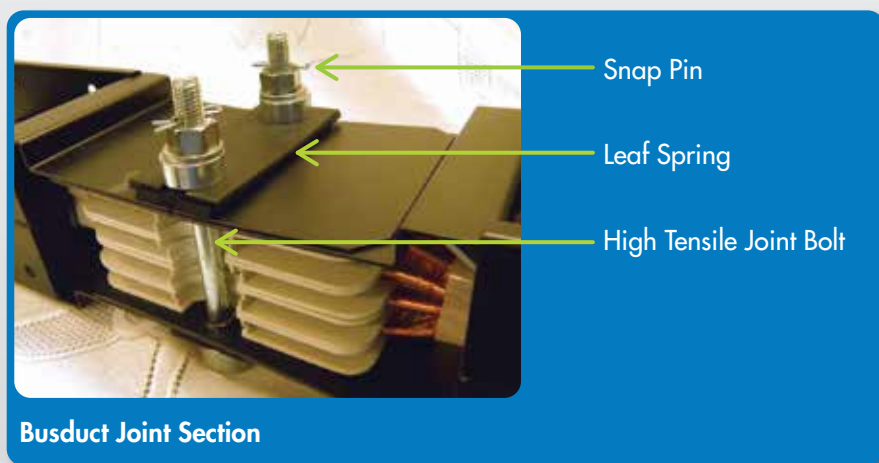

2.5 Inspection on Load Condition

After the busduct installation, increase of load is expected. An inspection has to be carried out to ensure that the total connected load does not exceed the rated current of the busduct before the load is increased.

2.6 Measurement of Insulation Resistance

Measure the insulation resistance between each conductor and between conductor and housing. When the measurement is carried out, the electrical loads and connected equipment shall be disconnected.

2.7 Inspection on Rust or Peeling of Paint on Busduct Housing

If there are sign of peeling paint or rust on the busduct housing, cleaning work and touch-up painting are recommended.

The metal housing / enclosure of busduct must not be dismantled by any parties without the official authorization from the manufacturer for any purposes. Any violation or abuse will result the respective party to be responsible for all the consequences and compensation. Furthermore, the manufacturer reserves the right to void the warranty if any violation or abuse occurs to the busduct system.

AH BUSDUCT

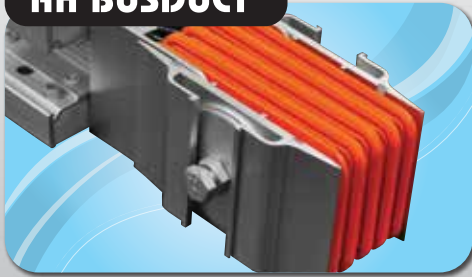

- Extruded Aluminium-Alloy Housing
- Compact Sandwich Type
- Excellent Heat Dissipation
- Corrosion Resistant
- Low Impedance Ground Path
(with electrical conductivity of more than 50% IACS)
- Light Weight and Easy Installation
- Type Tested to IEC 61439-6
- Maintenance-Free
- EMF and EMC verified

HP-ES BUSDUCT



- Inherited Japanese Design & Technology
- Double Bolt Joint Design
- Compact Sandwich Type
- Electro Galvanized Steel with Epoxy Powder Coating
- Polyester Film Insulated
- Type Tested to IEC 61439-6 and Certified by DEKRA / KEMA Quality
- Fire Resistance certified to BS 6387 and CNS 14286 (Equivalent to JIS C 8364 and JIS A 1304)
- Weather Shield Design for Outdoor Installation
- Eco-Labeling certified to MS 2237:2009 as an Environmental Friendly Product
- Maintenance-Free
- Experienced in the Stringent Requirement of Data Centre
- BIM Ready - REVIT
- EMF and EMC verified

CR BUSDUCT



- Corrosion resistant & Self Extinguished Cast Resin Type
- Applicable to Low, Medium and High Voltage Requirement
- Type Tested to IEC 60439-2 (LV) and IEC 62271-200 (MV)
- Degree of Protection certified to IP68
- Fire Resistance certified to CNS 14286 (Equivalent to JIS C 8364 and JIS A 1304)
- IK10 Mechanical Impact certified to IEC 62262
- Seismic Protection certified to withstand 2.2g Peak Ground Acceleration (PGA)
- Overload current capacity of 25% for 4 hours
- Aluminium Profile along busduct body ensuring earth continuity
- Certified as Environmental Friendly Product
- Maintenance-Free
- EMF and EMC verified



Lot 4, Block A, Jalan SS13/7
Subang Jaya Industrial Estate
47500 Subang Jaya
Selangor Darul Ehsan, Selangor
Tel: +603-56357088 Fax: +603-56356099
Website: www.eita.com.my

FURUTEC[®] Electrical Sdn. Bhd. (057207-W)

(A member of EITA Resources Berhad)
Plot 89, Lorong Perindustrian Bukit Minyak 11,
Kawasan Perindustrian Bukit Minyak,
MK 13, 14100 Seberang Perai Tengah, Penang, Malaysia
Tel: +604-508 0228 Fax: +604-508 0227
E-mail: furutec@eita.com.my
Website: www.furutec.com.my

Sales & Marketing contact :

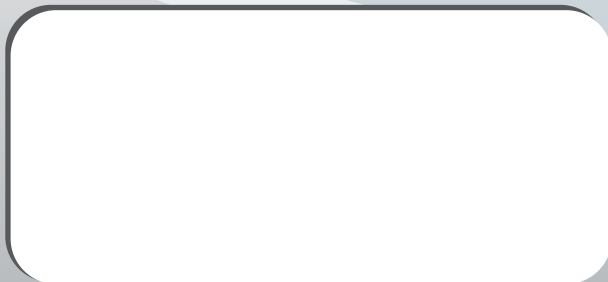

SIRIM
ECO-LABEL



Certificate No.7515

